

MENIOTA

NORTH AMERICA'S LUXURY FIREPLACE

Installation and Operating Instructions

MODEL NO. AA-11-04152 DXV35DT4 DIRECT VENT GAS FIREPLACE HEATER

INSTALLER: Leave this manual with the appliance
CONSUMER: Retain this manual for future reference

INSTALLATEUR : Laissez ce manuel avec l'appareil
CONSOMMATEUR : Conservez ce manuel pour référence future

▲ WARNING:

FIRE OR EXPLOSION HAZARD

Failure to follow safety warnings exactly could result in serious injury, death, or property damage.

▲ AVERTISSEMENT:

RISQUE D'INCENDIE OU D'EXPLOSION

Le non-respect des avertissements de sécurité à la lettre peut entraîner des blessures graves, la mort ou des dommages matériels.

- Do not store or use gasoline or other flammable vapors and liquids in the vicinity of this or any other appliance.

- WHAT TO DO IF YOU SMELL GAS

- Do not try to light any appliance.
- Do not touch any electrical switch; do not use any phone in your building.
- Immediately call your gas supplier from a neighbor's phone. Follow the gas supplier's instructions.
- If you cannot reach your gas supplier, call the fire department.

- Installation and service must be performed by a qualified installer, service agency or the gas supplier.

Ne pas entreposer ni utiliser d'essence ni d'autres vapeurs ou liquides inflammables dans le voisinage de cet appareil ou de tout autre appareil.

- QUE FAIRE SI VOUS SENTEZ UNE ODEUR DE GAZ:

- Ne pas tenter d'allumer d'appareil.
- Ne touchez à aucun interrupteur. Ne pas vous servir des téléphones se trouvant dans le bâtiment où vous trouvez.
- Appelez immédiatement votre fournisseur de gaz depuis un voisin. Suivez les instructions du fournisseur.
- Si vous ne pouvez rejoindre le fournisseur de gaz, appelez le service des incendies.

- L'installation et l'entretien doivent être assurés par un installateur ou un service d'entretien qualifié ou par le fournisseur de gaz.

This appliance may be installed in an aftermarket, permanently located, manufactured home (USA only) or mobile home, where not prohibited by local codes.

This appliance is only for use with the type of gas indicated on the rating plate. This appliance is not convertible for use with other gasses, unless a certified kit is used.

Cet appareil peut être installé dans une maison préfabriquée (É.-U. seulement) ou mobile déjà installée à demeure si les règlements locaux le permettent. Cet appareil doit être utilisé uniquement avec les types de gaz indiqués sur la plaque signalétique. Une trousse de conversion est fournie avec cet appareil.

A barrier designed to reduce the risk of burns from the hot viewing glass is provided with this appliance and must be installed.

Une barrière conçue pour réduire le risque de brûlures du verre chaud est fournie avec cet appareil et doit être installée.

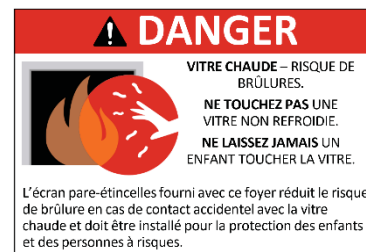
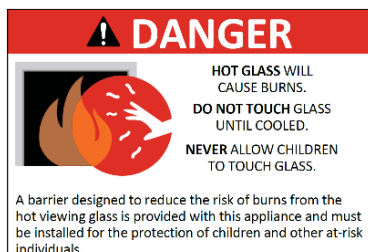

1 READ ME FIRST

1.1 CAUTION STATEMENTS TO PARENTS OF YOUNG CHILDREN

If this fireplace is installed in an isolated bedroom, study or other room, always operate this appliance in thermostatic temperature-controlled mode. Do not operate in Manual mode. Doing so can lead to very high room temperatures which can be hazardous to the room occupants' health.

Do not place young children in cribs, bassinets or the like in the vicinity of this appliance. Young children may be vulnerable to high temperatures that this fireplace can create locally.

Young children should be **carefully supervised** and never left unattended when they are in the same room as the fireplace. Toddlers, young children and others may be susceptible to accidental contact burns. A physical barrier is recommended if there are at risk individuals in the house. To restrict access to a fireplace or stove, install an adjustable safety gate to keep toddlers, young children and other at-risk individuals out of the room and away from hot surfaces. This physical barrier is in addition to the required glass barrier Screen.

1.2 INITIAL FIRING AND CURING PROCEDURE

This product requires an initial heat curing cycle during which some materials used in the manufacturing process will burn off and the powder paint goes through a hardening cycle. During the initial curing phase, some smoke and odor will be emitted. This is normal.

The installer should perform these initial curing cycle procedures as the final step in the installation process before finishing materials are installed around this fireplace. See chapter [3.1.1 Mendota Fireplace Curing Instructions](#). Read and follow all instructions given in this Chapter and perform the 3-step curing cycle.

After the 3-step curing cycle has been completed, all smoking will have stopped. Some slight odors may remain. With subsequent use of this Fireplace, odors will slowly dissipate and disappear.

ODOR RISKS

If this appliance is not operated for an extended period (three months or longer), when first fired again, expect odors of burnt dust and lint; just like when turning on your home heating system for the first time in the Fall.

1.3 HOT SURFACES ARE NORMAL

Be aware that the surface in front of, above and adjacent to this heater appliance can be too hot to touch. As long as all required clearances to combustibles are met and the required finishing materials are used, this appliance will perform safely. Note that the exposed surfaces immediately surrounding the Fireplace can have surface temperatures that are too hot to touch. This level of surface temperature is considered normal and does not indicate any hazardous situation.

WARNING: The supplied barrier screen must be installed, always, when this fireplace is in operation. Do not place any object directly in front (within 60") or directly above (on the front edge of the mantel). This is a heating appliance. Areas directly in front and above this appliance will be very hot and can damage most household objects if placed too close. Keep Furniture pieces at least 60" away in front of the barrier screen.

1.4 PERIODIC AND ANNUAL CLEANING ARE REQUIRED

See [Required Periodic Inspections, Chapter 6.1](#) and [Required Annual Maintenance, Chapter 6.3](#). Periodic and Annual cleaning and general services are required at least once a year in the Summer or early Fall. Changing remote control batteries at least every 6 months is required; or more frequently based upon usage frequency. Cleaning pilot flame sensor rod, sparker rod and pilot hood body is required at least once per year. Cleaning of burner ports, gas orifice areas is required once a year due to insects' nesting probability due to Mercaptan addition in Natural Gas (Mercaptan attracts insects).

Table of Contents

1	READ ME FIRST	2		
1.1	CAUTION STATEMENTS TO PARENTS OF YOUNG CHILDREN..	2		
1.2	INITIAL FIRING AND CURING PROCEDURE	2		
1.3	HOT SURFACES ARE NORMAL	2		
1.4	PERIODIC AND ANNUAL CLEANING ARE REQUIRED	2		
2	GENERAL INFORMATION.....	5		
2.1	SAFETY AND WARNING INFORMATION	5		
2.1.1	Building Permit & Inspection Requirements	5		
2.1.2	Other Cautions	5		
2.2	SAFETY WARNINGS.....	6		
2.2.1	Safety Standards and Warnings	7		
2.2.2	Requirements for The Commonwealth of Mass. ...	9		
3	TECHNICAL REFERENCES	10		
3.1	GENERAL TECHNICAL REFERENCES	10		
3.1.1	Mendota Fireplace Curing Instructions.....	11		
3.1.1.1	Step 1: Expelling Initial Smoke and Odors.....	11		
3.1.1.2	Step 2: High Heat Curing Cycle.....	11		
3.1.1.3	Step 3: Final Curing Cycle.....	11		
3.1.1.4	Additional Curing Information	11		
3.2	MECHANICAL TECHNICAL REFERENCES.....	12		
3.2.1	Labels	12		
3.2.1.1	Listing Label	12		
3.2.1.2	Other Warning and Caution Labels	13		
3.2.2	Planning the installation.....	14		
3.2.2.1	Selecting Appliance Location	14		
3.2.3	Dimensions and Technical Details.....	15		
3.2.3.1	DXV35DT4 Fireplace Ratings Information	15		
3.2.3.2	Fireplace Features.....	16		
3.2.3.3	Fireplace Dimensions and Clearances	17		
3.2.3.3.1	Hearth Pad Materials.....	18		
3.2.3.4	Rough Framing Dimensions	19		
3.2.3.5	Constructing the Appliance Chase	20		
3.2.4	Clearance Requirements	21		
3.2.4.1	Clearance from Appliance Body and Vent	21		
3.2.4.1	Hearth Pad Requirement	22		
3.2.4.1.1	Hearth Pad Materials.....	22		
3.2.4.2	Clearances to Combustible Mantels	23		
3.2.4.3	Clearances to Combustible Side Walls	24		
3.2.4.3.1	Horizontal Clearance Reduction by 66%.....	24		
3.2.4.3.2	Horizontal Clearance Reduction by 50%.....	24		
3.2.5	Normal Surface Temperatures	25		
3.2.5.1	Hearth Pad Temperatures.....	25		
3.2.5.2	Surround Face Temperatures	25		
3.2.5.3	Mantel Temperatures	25		
3.2.1	Suitable Mantel, Facing & Hearth Pad Materials .	26		
3.2.1.1	R-Values of Common Finishing Materials	26		
3.2.1.2	Smooth Wall	26		
3.2.1.3	Ceramic or Porcelain Tile	27		
3.2.1.4	Marble, Granite and Natural Stones	27		
3.2.1.5	Suitable Paints and Sealant Materials.....	28		
3.2.1.5.1	Paint Types Approved for Use	28		
3.2.1.5.2	Sealants Type Approved for Use.....	28		
3.2.1.5.3	Wood Application Cautions	28		
3.2.2	Recommendations for Television Installation.....	29		
3.2.2.1	Recommendation 1: Add a mantel.....	29		
3.2.2.2	Recommendation 2: Create a recessed cavity.....	30		
3.2.2.3	Recommendation 3: Install a heat transfer system.....	30		
3.2.2.3.1	Mendota Cool Wall31			
3.2.2.3.2	Versiheat	32		
3.2.2.3.3	FlexHeat	33		
3.2.3	Venting	34		
3.2.3.1	COMPONENT "TWIST-LOCK" CONNECTION PROCEDURE	34		
3.2.3.2	Wall Heat Shield for Horizontal Vent Caps	34		
3.2.3.3	Flue Venting Components Identification Diagrams	35		
3.2.3.4	Approved Vent Systems	36		
3.2.3.5	Exterior Vent Locations and Restrictions.....	37		
3.2.3.6	Side by Side installation of two Vent Caps	38		
3.3	ELECTRICAL TECHNICAL REFERENCES.....	39		
3.3.1	AC Power Requirements	39		
3.3.1.1	Planning for AC Power Connection	39		
3.3.1.2	AC Power Connection.....	40		
3.3.2	Backup DC Power Supply Information	41		
3.3.3	PF2 Ignition System Diagram	42		
3.4	PLUMBING TECHNICAL REFERENCES.....	43		
3.4.1	Gas Supply Requirements	43		
3.4.2	Gas Supply Line Sizing	43		
3.4.3	Gas Pressure Requirements and Checking.....	44		
3.4.4	Drip Leg Recommended	44		
3.4.5	Manual Gas Shutoff Valve Requirement	44		
3.4.6	Factory Installed Manual Gas Shutoff Valve	45		
3.4.7	Gas Inlet Fittings Information.....	45		
3.4.8	Gas Input Rate Verification	46		
3.4.8.1	Natural Gas Input Rate Verification.....	46		
3.4.8.2	LPG Input Rate Verification	46		
3.4.9	High Altitude De-Rating	46		
4	INSTALLATION INSTRUCTIONS.....	47		
4.1	INSTALLATION CHECKLIST.....	47		
4.2	PREPARING FOR INSTALLATION	48		
4.2.1	Unpacking the Fireplace.....	48		
4.2.2	Contents of the Manual Packet.....	49		
4.2.3	What is not included with this Appliance?.....	49		
4.2.4	Unbolting Fireplace from Pallet	49		
4.2.5	Bending up the shipping clips.....	50		
4.2.6	How to Remove Door	51		
4.2.7	How To Replace Door.....	51		
4.3	LIGHT BULB AND LIGHT LENS INSTALLATION	52		
4.4	NATURAL GAS TO LPG CONVERSION	53		
4.4.1	Procedure to Convert Fireplace for LP Gas	53		
4.4.2	Pressure Regulator Conversion	55		
4.4.3	Burner Ignition Characteristics.....	56		
4.4.4	Pilot Flame and Burner Relationship Verification	56		

4.5	VENTING.....	57	5.7.1	Safety Information	72
4.5.1	Wall Thimble Information	57	5.8	OPERATING INSTRUCTIONS.....	72
4.5.2	DXV35DT4 Master Venting Chart.....	58	5.9	TO TURN OFF GAS TO FIREPLACE	72
4.5.3	High Altitude Installation Information	58	5.10	FREQUENTLY ASKED QUESTIONS	73
4.5.4	Maximum Horizontal Run	59	5.10.1	What to do if I smell gas?	73
4.5.5	Maximum Vent System Length	59	5.10.2	Where can I find the model and serial numbers? 73	
4.5.6	How to Calculate the Vent Lengths.....	59	5.10.3	Can I use my Fireplace during power outages?....	74
4.5.7	Using 90° Elbows	59	5.10.4	What maintenance is required?.....	74
4.5.8	Using 90° Elbows When the Initial Starter Vertical Section Is Less Than 4'	59	5.10.4.1	Required Annual Maintenance.....	74
4.5.9	Using 45-Degree Elbows	59	5.10.4.2	Periodic Inspection.....	75
4.5.10	Minimum Rise Horizontal Termination	60	5.10.5	How do I clean the viewing glass?.....	75
4.5.11	Elevated Vertical Rise Through-The-Wall Venting 61		5.10.6	Is my flame performance correct?	75
4.5.12	Vertical Through-The Roof Venting.....	62	5.10.7	What should I do if my fireplace is sooting?	75
4.5.13	Vent Damper Adjustments.....	63	5.10.8	How do I change from Celsius to Fahrenheit?	75
4.6	POWER VENTING	63	5.10.9	When do I change batteries in my remote?.....	76
4.6.1	VENT PIPE.....	63	5.10.10	How do I set the child-lock mode?.....	76
4.6.2	VENT STARTER HEIGHT REQUIREMENT	63	5.10.11	Thermostat icon disappeared from my remote.	76
4.6.3	Approved Vent Systems	64	5.10.12	Why won't my fireplace turn on?	76
4.6.4	Power Vent Exterior Vent Locations and Restrictions.....	65	5.10.13	What happens when I first light my fireplace? ..	76
4.7	LOG SET/ MEDIA INSTALLATION	65	6	MAINTENANCE INFORMATION.....	77
4.8	LIGHTING CHECKLIST.....	66	6.1	REQUIRED PERIODIC INSPECTIONS	77
4.9	AIR SHUTTER CONTROL AND FLAME APPEARANCE	66	6.2	CLEANING VIEWING GLASS.....	77
5	HOMEOWNER INFORMATION	67	6.3	REQUIRED ANNUAL MAINTENANCE	77
5.1	AESTHETIC CONSIDERATIONS	67	6.4	OVER FIRING OR UNDER FIRING OF BURNER	78
5.2	HEATING PERFORMANCE.....	67	6.5	IGNITION SYSTEM LOCKOUT MODE AND RE-LIGHTING	78
5.3	IMPORTANT INFORMATION FOR HOMEOWNER	67	6.6	BURNER FLAME HEIGHTS REFERENCE DIAGRAM	78
5.3.1	Using Your Remote Control.....	67	6.7	REPLACEMENT PARTS INFORMATION.....	79
5.3.2	Synchronizing the Fireplace and Remote Control 67		6.7.1	How to Access Components.....	79
5.3.3	Remote Control Functions	68	6.7.2	General Replacement Parts List	79
5.4	REMOTE CONTROL OPERATING INSTRUCTIONS.....	69	6.7.3	Convection Air Blower System Parts	80
5.4.1	To Turn on the Fireplace	69	6.7.4	Accent Light Parts.....	80
5.4.2	To Turn off the Fireplace.....	69	6.7.5	Valve Assembly Replacement Parts	81
5.4.3	Understanding Your Remote-Control Icons	69	6.7.6	Glass Frame Parts Replacement Procedure	82
5.4.4	Icon Details.....	70	7	WARRANTY QUALIFICATION AND SERVICE	83
5.5	IPI AND PILOT ON DEMAND MODES.....	71	7.1	FINAL INSTALLATION AND HOMEOWNER CHECKLIST	84
5.5.1	Setting to IPI or CPI mode	71	7.2	WARRANTY POLICY STATEMENT.....	85
5.6	HOW DO I CHANGE FROM CELSIUS TO FAHRENHEIT?.....	71	7.2.1	Conditions	86
5.7	FIRST TIME LIGHTING INSTRUCTIONS	72	7.2.2	Exclusions	86
			7.2.3	Limitations of Liability	87
			7.2.4	How to Obtain Warranty Service	87

2 GENERAL INFORMATION

2.1 SAFETY AND WARNING INFORMATION

2.1.1 Building Permit & Inspection Requirements

All installations of Mendota Fireplaces must comply with all the requirements stated in this Installation and Operating Manual. The dealer and/or installer must obtain all required building permits and inspection approvals from the local building inspection department or the local jurisdiction. To validate warranty coverage, Mendota may require facsimile copies of the building permit and inspection approval forms. Failure to provide adequate proof that the installation conforms to all local requirements and the requirements stated in the Installation and User Manual will void all applicable warranties.

2.1.2 Other Cautions

This fireplace is not intended for outdoor installation. The fireplace must be installed where it is fully protected from all precipitation, excessive moisture, and the ambient temperature remains between 32°F to 110°F. Failure to install the fireplace in an area that meets these requirements will void all applicable warranties.

CAUTION: Each installation must conform to all local, state and national codes. Refer to the national fuel gas code and local zoning and code authorities for details on installation requirements. The Mendota Fireplace must be vented to the outside in accordance with the latest edition of the National Fuel Gas Code. In the absence of local codes, the installation must conform to the most current edition of the National Fuel Gas Code ANSI Z223.1/NFPA 54 or the Natural Gas and Propane Installation Code, CSA B149.1

CAUTION: The Mendota Fireplace may be installed in a manufactured (mobile) home after the first sale of the home. Manufactured home (mobile home) installation must conform with the Manufactured Home Construction and Safety Standard, Title 24 CFR, Part 3280, or, when such a standard is not applicable, the Standard for Manufactured Home Installations, ANSI A225.1/NFPA 501A, or CSA Z240.4-Gas Equipped Mobile Housing. Consult your local building official. NOTE: For mobile home installations, unit must be bolted to the Manufactured home floor and properly grounded.

NATIONAL
FIREPLACE
INSTITUTE®



CERTIFIED
www.nficertified.org

**We recommend that our gas
Hearth products be installed
and serviced by profess-
ionals who are certified in
the U.S. by the National
Fireplace Institute® (NFI) as
CERTIFIED NFI Gas Specialists.**

INSTALLER: Leave this manual with the appliance. **CONSUMER:** Retain this manual for future reference.

INSTALLATEUR : Laissez cette notice avec l'appareil. **CONSOMMATEUR :** Conservez cette notice pour consultation ultérieure.

2.2 SAFETY WARNINGS

HIGH-ALTITUDE INSTALLATION INFORMATION: Prior to installing at altitudes higher than 7,500 ft., understand the need for gas input derating. Contact your local gas company to see if your gas type is already derated for your altitude or contact Mendota Technical Service for support.

INSTALLER NOTE: These instructions are to remain with homeowner.

Be sure to read and understand all instructions carefully before starting the fireplace. Failure to follow these instructions may result in a possible fire hazard leading to property loss, injury or even death and will void all warranty.

FOR YOUR SAFETY: A qualified installer, service agency, or the gas supplier must perform installation and service.

Do not store or use gasoline or other flammable vapors and liquids in the vicinity of this or any other appliance.

WARNING: Do not operate this appliance with the glass removed, cracked or broken. A licensed or qualified person should do replacement of glass.

AVERTISSEMENT: Ne pas utiliser l'appareil si le panneau frontal en verre n'est pas en place, est craqué ou brisé. Confiez le remplacement du panneau à un technicien agréé.

WARNING: Mendota gas fireplaces are heat producing appliances. Do not burn wood, paper or other materials in this fireplace. This fireplace is designed as a supplemental heat source. It is advisable to have an alternative primary heat supply.

In the Commonwealth of Massachusetts:
Installation must be performed by a licensed plumber or gas fitter; a CO detector shall be installed in the room where the appliance is installed.

WARNING: Improper installation, adjustment, alteration, service or maintenance can cause injury or property damage. Refer to this manual. For assistance or additional information consult a qualified installer, service agency or the gas supplier.

This appliance may be installed in an aftermarket, permanently located, manufactured (mobile) home (USA Only), where not prohibited by local codes. This appliance is only for use with the type(s) of gas indicated on the rating plate. This appliance is not convertible for use with other gases, unless a certified conversion kit is used.

Cet appareil peut être installé dans un maison préfabriquée (mobile) déjà installée à demeure si les règlements locaux le permettent.

Cet appareil doit être utilisé uniquement avec les types de gas indiqués sur la plaque signalétique. Ne pas l'utiliser avec d'autres gas sauf si un kit de conversion certifié est installé.

2.2.1 Safety Standards and Warnings

Do not operate this appliance with the glass removed, cracked or broken. Only glass doors certified with this appliance shall be used.

A barrier designed to reduce the risk of burns from the hot viewing glass is provided with this appliance and must be installed. If the barrier becomes damaged, the barrier shall be replaced with the manufacturer's barrier for this appliance.

Any Barrier Screen or guard removed for servicing must be replaced before operating fireplace.

Tout écran ou protecteur retiré pour permettre l'entretien de l'appareil doit être remis en place avant de mettre l'appareil en marche.

This unit is not for use with solid fuel.

Ne pas utiliser avec du combustible solide.

Installation and repair should be **performed** by a qualified service person. The fireplace and venting system should be **inspected** before initial use and at least annually by a professional service person. More frequent cleaning may be required due to excessive lint from carpeting, bedding, material, etc. It is imperative that the unit's control compartment, burners and circulating air passageways are **kept clean** to provide for adequate combustion and ventilation air.

L'installation et la réparation devrait être confiées à un technicien qualifié. L'appareil devrait faire l'objet d'une inspection par un technicien professionnel avant d'être utilisé et au moins une fois l'an par la suite. Des nettoyages plus fréquents peuvent être nécessaires si les tapis, la literie, et cetera produisent une quantité importante de poussière. Il est essentiel que les compartiments abritant les commandes, les brûleurs et les conduits de circulation d'air de l'appareil soient tenus propres.

Always keep the fireplace clear and free from combustible materials, gasoline, and other flammable vapors and liquids.

Never obstruct the flow of combustion and ventilation air. Keep the front of the fireplace clear of all obstacles and materials for servicing and proper operation. Use only Mendota approved Screens, Fronts and Trim Kits.

Due to high temperature, the fireplace **should be located out of traffic areas** and away from furniture and draperies. En raison des températures élevées, l'appareil devrait être installé dans un endroit où il y a peu de circulation et loin du mobilier et des tentures.

Clothing or flammable material should not be placed on or near the fireplace.

On ne devrait pas placer de vêtements ni d'autres matières inflammables sur l'appareil ni à proximité.

Children and adults should be **alerted** to the hazards of high surface temperature and should **stay away** to avoid burns or clothing ignition. The door glass, surrounding walls and objects can be too hot to touch.

Les enfants et les adultes devraient être informés des dangers que posent les températures de surface élevées et se tenir à distance afin d'éviter des brûlures ou que leurs vêtements ne s'enflamment.

Young children should be **carefully supervised** when they are in the same room as the fireplace. Toddlers, young children and others may be susceptible to accidental contact burns. A physical barrier is recommended if there are at risk individuals in the house. To restrict access to a fireplace or stove, install an adjustable safety gate to keep toddlers, young children and other at-risk individuals out of the room and away from hot surfaces. This physical barrier is in addition to the required glass barrier Screen.

Les jeunes enfants devraient être surveillés étroitement lorsqu'ils se trouvent dans la même pièce que l'appareil. Les tout petits, les jeunes enfants ou les adultes peuvent subir des brûlures s'ils viennent en contact avec la surface chaude. Il est recommandé d'installer une barrière physique si des personnes à risques habitent la maison. Pour empêcher l'accès à un foyer ou à un poêle, installez une barrière de sécurité; cette mesure empêchera les tout petits, les jeunes enfants et toute autre personne à risque d'avoir accès à la pièce et aux surfaces chaudes.

These units **must** use one of the vent systems described in the Flue Venting section of this manual.

This gas fireplace and vent system **must** be vented directly to the outside and **must never** be attached to a chimney serving a separate solid fuel-burning fireplace. Each gas fireplace **must use** a separate vent system. Common vent systems are **prohibited**.

The vent system for this fireplace must be periodically examined by a qualified service agency to maintain venting performance and safety. If the vent-air intake system is disassembled for any reason, reinstall per the instructions provided for the initial installation.

Inspect the external vent cap on regular basis (monthly) to make sure that no debris is interfering with the airflow. The flow of combustion and ventilation air are not to be obstructed.

Do not abuse the glass door assembly by striking the glass, slamming the door shut, etc.

Use only authorized parts and materials obtained from Mendota Hearth when replacing defective or damaged glass, log sets, media, firebox inner liners or trim kits.

Do not use abrasive cleaners on the glass door assembly. Do not attempt to clean the glass door when it is hot. Use Mendota recommended cleaner, KelKem.

Turn off the gas before servicing this fireplace. It is recommended that a qualified service technician perform a fireplace check-up at the beginning of each heating season.

Do not place furniture or any other combustible household objects within 60" of the fireplace front, per fire safety code.

This vented gas fireplace heater is not for use with air filters.

Foyer au gaz à évacuation. - Ne pas utiliser avec du combustible solide.

Keep burner and control compartment clean. See installation and operating instructions accompanying fireplace.

S'assurer que le brûleur et le compartiment des commandes sont propres. Voir les instructions d'installation et d'utilisation qui accompagnent l'appareil.

WARNING: Improper installation, adjustment, alteration, service or maintenance can cause injury or property damage. Refer to the owner's information manual provided with this fireplace. For assistance or additional information consult a qualified installer, service agency or the gas supplier.

L'AVERTISSEMENT: L'installation inconvenante, ajustement, modification, service ou entretien peut causer le dommages de propriété ou blessure. Référer au manuel d'information de propriétaire fourni cet appareil. Pour l'assistance ou information supplémentaire consulte un qualifiée installateur, agence de service ou le fournisseur de gaz.

Do not use this fireplace if any part has been under water. Immediately call a qualified service technician to inspect the fireplace and to replace any part of the control system and any gas control, which has been underwater.

Ne pas utiliser cet appareil s'il a été plongé, même partiellement, dans l'eau. Appeler un technicien qualifié pour inspecter l'appareil et remplacer toute partie du système de commande et toute commande qui a été plongée dans l'eau.

Do not use any fronts or doors with this fireplace unless they are certified by Mendota and installed by a certified installer.

Seules des portes certifiées pour cet appareil doivent être utilisées.

2.2.2 Requirements for The Commonwealth of Mass.

The information in this section applies to all installations performed in the Common Wealth of Massachusetts only.

- a. For all side wall, horizontally vented gas fueled equipment installed in every dwelling, building or structure used in whole or in part for residential purposes and where the side wall exhaust vent termination is less than seven (7) feet above grade, the following requirements shall be satisfied:
 1. If there is no carbon monoxide detector with an alarm already installed in compliance with the most current edition of NFPA 720, NFPA 70 and the Massachusetts State Building code in the residential unit served by the side wall horizontally vented gas fueled equipment, a battery-operated carbon monoxide detector with an alarm shall be installed in compliance with the most current edition of NFPA 720, NFPA 70 and the Massachusetts State Building Code.
 2. In addition to the above requirements, if there is not one already present, a carbon monoxide detector with an alarm and a battery backup shall be installed and located in accordance with the installation requirements supplied with the detector on the floor level where the gas equipment is installed. The carbon monoxide detector with an alarm shall comply with 527 CMR, ANSI/UL 2034 Standards or CSA 6.19 and the most current edition of NFPA 720. In the event that the requirements of this subdivision cannot be met at the time of the completion of the installation of the equipment, the installer shall have a period of thirty (30) days to comply with this requirement; provided, however, that during said thirty (30) day period, a battery-operated carbon monoxide detector with an alarm shall be installed in compliance with the most current edition of NFPA 720, NFPA 70 and the Massachusetts State Building Code. In the event that the horizontally vented gas fueled equipment is installed in a crawl space or an attic, the carbon monoxide detector may be installed on the next adjacent habitable floor level. Such detector may be a battery-operated carbon monoxide detector with an alarm and shall be installed in compliance with the most current edition of NFPA 720, NFPA 70 and the Massachusetts State Building Code.
 3. A metal or plastic identification plate shall be permanently mounted to the exterior of the building at a minimum height of eight (8) feet above grade directly in line with the exhaust vent terminal for the horizontally vented gas fueled heating appliance or equipment. The sign shall read, in print size no less than one-half (1/2)" in size, "GAS VENT DIRECTLY BELOW, KEEP CLEAR OF ALL OBSTRUCTIONS"
 4. A final inspection by the state or local gas inspector of the side wall horizontally vented equipment shall not be performed until proof is provided that the state or local electrical inspector having jurisdiction has granted a permit for installation of carbon monoxide detectors and alarms as required above.
- b. EXEMPTIONS: The following equipment is exempt from 248 CMR 5.08(2) (a) 1 through 4:
 1. The equipment listed in Chapter 10 entitled "Equipment Not Required To Be Vented" in the most current edition of NFPA 54 as adopted by the Board; and
 2. Product Approved side wall horizontally vented gas fueled equipment installed in a room or structure separate from the dwelling, building or structure used in whole or in part for residential purposes.
- c. When the manufacturer of Product Approved side wall horizontally vented gas equipment provides a venting system design or venting system components with the equipment, the instructions for installation of the equipment and the venting system shall include:
 1. A complete parts list for the venting system design or venting system; and
 2. Detailed instructions for the installation of the venting system design or the venting system components.
- d. When the manufacturer of a Product Approved side wall horizontally vented gas fueled equipment does not provide the parts for venting the flue gases, but identifies "special venting systems", the following shall be satisfied:
 1. The referenced "special venting system" instructions shall be included with the appliance or equipment installation instructions; and
 2. The "special venting systems" shall be Product Approved by the Board, and the instructions for that system shall include a parts list and detailed installation instructions.
- e. A copy of all installation instructions for all Product Approved side wall horizontally vented gas fueled equipment, all venting instructions, all parts lists for venting instructions, and/or all venting design instructions shall remain with the appliance or equipment at the completion of the installation

3 TECHNICAL REFERENCES

Read and understand all information provided under this section, Technical References, before you begin the installation of this product. Failure to follow all technical reference information, use of components or parts not approved, or use of improper installation procedures can lead to a fire or explosion causing property damage, personal injury or loss of life.

3.1 GENERAL TECHNICAL REFERENCES

Caution: Before igniting the pilot or burners, perform the following inspections and verifications:

Check glass gasket seal. Visually inspect glass gasket, especially at the corners of the glass piece. Glass gasket is installed as a 4-piece assembly. Check joints between the gasket pieces at the corners. They should butt against each other to create a seal. Gaps between gasket pieces can cause exhaust leaks and lead to acrid smell concerns. Check for gas leaks at all fittings. During the first burning cycle of this Fireplace, ensure the convection blower is running at level three during the first two hours of initial burn. After two hours of initial burn, allow fireplace to cool. **Proceed with [Mendota Fireplace Curing Instructions, Chapter 3.1.1.](#)**

WARNING **FIRE RISK/ODOR RISK**

- This fireplace must be installed on top of wood, masonry or metal floor extending the full width and depth of this fireplace.
- An R-1 Rated Hearth Protection Pad, 12" deep, is required unless this fireplace is elevated at least 6" above floor level of the room. For every 1" this fireplace is elevated, you may reduce the hearth pad depth by 2". Locate and install appliance to all clearance specifications in manual.
- Verify glass gasket seal before firing unit the first time. Verify proper latching of glass frame onto unit body.
- Understand that this appliance requires a break-in period during which small amounts of smoke and curing smells will be emitted.

This fireplace must be installed and serviced by a qualified installer, service agency, or the gas supplier. Any adjustments to burner, pilot, logs or coal bed must be made by a qualified installer, service agency, or the gas supplier.

If ignition system goes into lockout mode, always wait 5 minutes before attempting to re-light.

Never block off convection air openings or paths. Trim panels or surrounds shall not seal ventilation openings in the fireplace. Always use Mendota decorative fronts and Mendota approved vent systems and vent caps only.

Keep the flue warm

It is required to activate the Continuous Pilot Mode (CPI) to leave the pilot light running during winter months when outside daily high temperatures remain 50°F or lower. Doing so will eliminate heat loss from the home through the Fireplace glass door and will increase flue draft during startups and will aid in eliminating system lock out.

3.1.1 Mendota Fireplace Curing Instructions

ATTENTION

It is important that the blowers are turned on during this step to prevent the curing smoke from staining the wall finish above the fireplace. Mendota recommends completing Step 1 prior to installation of wall finish materials.

Visible smoke and strong odor are to be expected during this step. If desired, disable smoke alarms before this step, smoke from the initial curing cycle will set off smoke alarms. Open doors and windows of the home to circulate fresh air.

3.1.1.1 Step 1: Expelling Initial Smoke and Odors

- Please refer to [Chapter 5.8 Operating Instructions](#), if you have questions on how to operate your Mendota.
- Complete the installation of any barrier screen (required), surround, front or doors.
- Turn the fireplace on in the Manual (Off) thermostat mode.
- Set the Flame Height to Hi.
- Set the Fan Speed Control to Level 3.
- Run the fireplace with these settings for a minimum of 2 hours.
- Turn the fireplace off and let it cool.

3.1.1.2 Step 2: High Heat Curing Cycle

- Turn the fireplace on in the Manual (Off) thermostat mode.
- Set the Flame Height to Hi.
- Set the Fan Speed Control to Off.
- Run the fireplace with these settings until curing odors have diminished.
- When odors have diminished leave the fireplace turned on and continue to Step 3.

3.1.1.3 Step 3: Final Curing Cycle

- With the fireplace still turned on from Step 2.
- Set the Fan Speed Control to the lowest setting Level 1.
- If any new curing odors are detected, continue to run the fireplace with this setting until the curing odors have diminished.

ATTENTION: Slight odors may still be noticeable on future startups of the fireplace. These will diminish over time as the fireplace is used.

3.1.1.4 Additional Curing Information

It is not unusual for a fireplace to require more than 10 continuous hours on high for curing odors to diminish. There are variables that can extend or shorten the curing time such as decorative fronts, doors, facing materials and their application. Finish materials around the fireplace are subject to high temperatures. Finishing materials used over the fireplace in the non-combustible zone can see temperatures around 350° F. Materials used around the fireplace must be rated for these temperatures. Failure to use adequate materials can result in odor problems. Please refer to [Chapter 3.2.4.1](#) of this manual for information on appropriate finishing materials.

Please be aware that materials used around the fireplace will heat up and have the potential to cause odor issues. Adhesives, glue, wall substrate, wall finish material, paints and polishes are common materials that if used incorrectly will cause odor issues. Mendota is not responsible for any odor issues caused by materials used around the fireplace.

3.2 MECHANICAL TECHNICAL REFERENCES

3.2.1 Labels

3.2.1.1 Listing Label

The listing label is in the air gap beneath the firebox behind the lower grill of the Fireplace. It is secured to a chain and can be pulled out to be viewed.



NORTH AMERICA'S LUXURY FIREPLACE

⚠ DANGER



HOT GLASS WILL CAUSE BURNS. DO NOT TOUCH GLASS UNTIL COOLED. NEVER ALLOW CHILDREN TO TOUCH GLASS.

VITRE CHAUDE - RISQUE DE BRÛLURES. NE TOUCHEZ PAS UNE VITRE NON REFROIDIE. NE LAISSEZ JAMAIS UN ENFANT TOUCHER LA VITRE.

A barrier designed to reduce the risk of burns from the hot viewing glass is provided with this appliance and must be installed for the protection of children and other at-risk individuals.

L'écran pare-étincelles fourni avec ce foyer réduit le risque de brûlure en cas de contact accidentel avec la vitre chaude et doit être installé pour la protection des enfants et des personnes à risques.

DIRECT VENT GAS FIREPLACE HEATER
(POELE AU GAZ HOMOLOGUÉ, À AÉRATION DIRECTE)
NOT FOR USE WITH SOLID FUEL
(NE DOIT PAS ÊTRE UTILISÉ AVEC UN COMBUSTIBLE SOLIDE)

MANUFACTURED BY (FABRIQUÉ PAR):
JOHNSON GAS APPLIANCE CO. HIAWATHA, IOWA
CERTIFIED FOR CANADA (HOMOLOGUE POUR LE CANADA)
CERTIFIED TO (CERTIFIÉ) ANSI Z21.88-2019(R2024) - CSA
2.33-2019(R2024) CATEGORY II APPLIANCE



Intertek
W/N 20784

Refer to the Intertek Directory of Building Products (<https://bpdirectory.intertek.com>) for detailed information.
Consultez l'Intertek Directory of Building Products (<https://bpdirectory.intertek.com>) pour des informations

WARNING: IMPROPER INSTALLATION, ADJUSTMENT, ALTERATION, SERVICE OR MAINTENANCE CAN CAUSE PROPERTY DAMAGE, PERSONAL INJURY, OR LOSS OF LIFE. REFER TO THE OWNER'S INFORMATION MANUAL PROVIDED WITH THIS APPLIANCE. INSTALLATION AND SERVICE MUST BE PERFORMED BY A QUALIFIED INSTALLER. THIS VENTED GAS APPLIANCE IS NOT FOR USE WITH AIR FILTERS. OPTIONAL REGISTER KIT'S AA-11-04732, AA-11-04734 AND AA-11-00390 MAY BE USED. OPTIONAL POWER VENTS AA-11-04071, AA-11-04072 AND AA-11-04100 MAY BE USED. FOR USE ONLY WITH GLASS BARRIER Part no. AA-11-02020

MISE EN GARDE: IMPROPRE INSTALLATION, UN RÉGLAGE, UNE MODIFICATION, UN ENTRETIEN OU UN ENTRETIEN INCORRECTS PEUVENT CAUSER DES DOMMAGES MATÉRIELS, DES BLESSURES CORPORELLES OU LA MORT. REPORTEZ-VOUS AU MANUEL D'INFORMATION DU PROPRIÉTAIRE FOURNI AVEC CET APPAREIL. L'INSTALLATION ET L'ENTRETIEN DOIVENT ÊTRE EFFECTUÉS PAR UN INSTALLATEUR QUALIFIÉ. CET APPAREIL À GAZ VENTILÉ N'EST PAS DESTINÉ À ÊTRE UTILISÉ AVEC DES FILTRES À AIR. LES KITS D'ENREGISTREMENT OPTIONNELS AA-11-04732, AA-11-04734 ET AA-11-00390 PEUVENT ÊTRE UTILISÉS. LES ÉVÉNEMENTS ÉLECTRIQUES AA-11-04071, AA-11-04072 ET AA-11-04100 PEUVENT ÊTRE UTILISÉS EN OPTION. À UTILISER UNIQUEMENT AVEC UNE BARRIÈRE EN VERRE N° de pièce AA-11-03777

WARNING: DO NOT OPERATE THE APPLIANCE WITH GLASS FRONT REMOVED, CRACKED OR BROKEN. REPLACEMENT OF THE PANEL(S) SHOULD BE DONE BY A LICENSED OR QUALIFIED SERVICE PERSON. FOR USE WITH GLASS DOORS CERTIFIED WITH THE APPLIANCE ONLY.

AVERTISSEMENT: NE PAS UTILISER L'APPAREIL SI LE PANNEAU FRONTAL EN VERRE N'EST PAS EN PLACE, EST CRAQUÉ OU BRISÉ. CONFIEZ LE REMPLACEMENT DU PANNEAU À UN TECHNICIEN AGRÉÉ. SEULES DES PORTES CERTIFIÉES POUR CET APPAREIL DOIVENT ÊTRE UTILISÉES.

	<input type="checkbox"/> NATURAL GAS (GAS DE PÉTROLE)	<input type="checkbox"/> LP GAS (GAZ NATUREL LIQUÉFIÉ (GPL))
INPUT RATING (BTR/HR) 0-2000ft (0-610m) (ENTRÉE NOMINALE)	33,000	33,000
MIN. INPUT RATING (BTU/HR) 0-2000ft (0-610m) (MINIMALE ENTRÉE NOMINALE)	10,000	13,000
ORIFICE 0-2000ft (0-610m) (FRONT/REAR)	#49/#44	3/64"/3/64"
ORIFICE 2000-4500ft (610-1370m) (FRONT/REAR)	#49/#45	3/64"/#55
INPUT RATING (BTU/HR) 2000-4500ft (610-1370m)	28,333	28,061
MAXIMUM OUTPUT (BTU/HR) (SORTIE MAXIMALE)	24,057	23,974
MANIFOLD PRESSURE (in. w.c./kPa) (PRESSION AU COLLECTEUR)	3.5 (0.87)	10.0 (2.5)
MANIFOLD PRESSURE, LOW (in. w.c./kPa) (PRESSION AU COLLECTEUR MINIMALE)	1.6 (0.4)	6.4 (1.59)
MINIMUM INLET PRESSURE (in. w.c./kPa) (PRESSION D'ENTRÉE MINIMALE)	5.0 (1.24)	11.0 (2.74)

THIS APPLIANCE IS ONLY FOR USE WITH THE TYPE OF GAS INDICATED ON THE RATING PLATE AND MAY BE INSTALLED IN AN AFTERMARKET, PERMANENTLY LOCATED, MANUFACTURED HOME (USA ONLY) OR MOBILE HOME, WHERE NOT PROHIBITED BY LOCAL CODES. SEE OWNER'S MANUAL FOR DETAILS. THIS APPLIANCE IS NOT CONVERTIBLE FOR USE WITH OTHER GASES, UNLESS A CERTIFIED KIT IS USED.

CET APPAREIL DOIT ÊTRE UTILISÉ UNIQUEMENT AVEC LE TYPE DE GAZ INDICUÉ SUR LA PLAQUE SIGNALÉTIQUE. CET APPAREIL PEUT ÊTRE INSTALLÉ DANS UNE MAISON PRÉFABRIQUÉE OU MOBILE (É.-U. SEULEMENT) INSTALLÉE À DEMEURE SI LES RÉGLEMENTS LOCAUX LE PERMETTENT. VOIR LA NOTICE DE L'UTILISATEUR POUR PLUS DE RENSEIGNEMENTS. CET APPAREIL NE PEUT PAS ÊTRE UTILISÉ AVEC D'AUTRES GAZ SAUF SI UNE TROUSSE DE CONVERSION CERTIFIÉE EST FOURNIE.

MINIMUM CLEARANCES TO COMBUSTIBLE CONSTRUCTION		
UNIT TO FLOOR	0 in.	GLASS EDGE TO ADJACENT SIDEWALL 12 in.
UNIT TO ENCLOSURE SIDEWALL	1/2 in.	VENT PIPE TOP TO COMBUSTIBLES 2 in.
UNIT TO ENCLOSURE BACK WALL	1/2 in.	VENT PIPE SIDES TO COMBUSTIBLES 1 in.
UNIT BOTTOM TO ENCLOSURE CEILING	53-3/8 in.	VENT PIPE BOTTOM TO COMBUSTIBLES 1 in.
UNIT FLOOR TO ROOM CEILING	72 in.	8" MANTLE ABOVE DISCHARGE AIR OPENING 14 in.

DÉGAGEMENTS MINIMAUX PAR RAPPORT AUX MATÉRIAUX COMBUSTIBLES		
UNITÉ AU PLANCHER	0 MM	BORD DU VITRAGE AU MUR LATÉRAL ADJACENT 305 MM
UNITÉ AU MUR LATÉRAL DE L'ENCEINTE	13 MM	DESSUS DU CONDUIT AUX MATÉRIAUX COMBUSTIBLES 50.8 MM
UNITÉ AU MUR ARRIÈRE DE L'ENCEINTE	13 MM	CÔTÉS DU CONDUIT AUX MATÉRIAUX COMBUSTIBLES 25 MM
DESSOUS DE L'UNITÉ AU PLAFOND DE L'ENCEINTE	1360 MM	DESSOUS DU CONDUIT AUX MATÉRIAUX COMBUSTIBLES 25 MM
PLANCHER DE L'UNITÉ AU PLAFOND DE LA PIÈCE	1830 MM	MANTEAU DE 8 PO AU-DESSUS DE LA SORTIE D'AIR 356 MM

CAUTION: HOT WHILE IN OPERATION. DO NOT TOUCH. KEEP CHILDREN, CLOTHING, FURNITURE, AND FLAMMABLE LIQUIDS OR VAPORS AWAY. KEEP GASOLINE AND OTHER LIQUIDS HAVING FLAMMABLE VAPORS AWAY. KEEP BURNER AND CONTROL COMPARTMENT CLEAN. SEE INSTALLATION AND OPERATING INSTRUCTIONS ACCOMPANYING APPLIANCE.

ATTENTION: L'APPAREIL EST CHAUD LORSQU'IL FONCTIONNE. NE PAS TOUCHER L'APPAREIL. SURVEILLER LES ENFANTS. GARDER

ELECTRICAL RATING (COURANT NOMINAL): 120 VOLTS 60 HERTZ LESS THAN 3.5 AMPERES

DO NOT REMOVE OR COVER THIS LABEL

VEUILLEZ A NE JAMES ENLEVER NI DISSIMULER CETTE ÉTIQUETTE

65-01-01421

MODEL: DXV-35 DT4 LX

SN: 4152-

Figure 3-1 Listing Label

3.2.1.2 Other Warning and Caution Labels

A few warnings or caution labels are attached to this appliance body as required per code to inform you of important facts. Make certain you heed all the warning and caution statements during installation and maintenance of this appliance.

This appliance must be installed in accordance with local codes, if any, if not; follow the National Fuel Gas Code, ANSI Z223.1 or Canadian Installation Codes, CAN/CGA B149".

«Installer l'appareil selon les codes ou règlements locaux, ou, en l'absence de tels règlements, selon les Codes d'installation CAN/CGA-B149

CAUTION:
HOT WHILE IN OPERATION. DO NOT TOUCH. SEVERE BURNS MAY RESULT.
KEEP CHILDREN, CLOTHING, FURNITURE, GASOLINE, AND OTHER LIQUIDS WITH FLAMMABLE VAPORS AWAY!
ATTENTION:
L'APPAREIL EST CHAUD LORSQU'IL FONCTIONNE. NE PAS TOUCHER L'APPAREIL.
SURVEILLER LES ENFANTS, GARDER LES VÊTEMENTS, LES MEUBLES, L'ESSENCE OU AUTRES LIQUIDES À VAPEUR INFLAMMABLES LOIN DE L'APPAREIL.

 **WARNING**

This product and the fuels used to operate this product (liquid propane or natural gas), and the products of combustion of such fuels, can expose you to chemicals including benzene, which is known to the State of California to cause cancer and reproductive harm. For more information, go to: www.P65Warnings.ca.gov.

65-01-01484

ONLY CONNECT 110 VAC POWER SUPPLY IN HERE

CONNECTER UNIQUEMENT UNE ALIMENTATION DE 110 VAC

THIS CONNECTION IS FOR LOW VOLTAGE BATTERY OR DIRECT CURRENT ONLY. DO NOT CONNECT TO 120 OR 240 VOLTS AC

CAUTION

Hot while in operation. Do not touch. Severe burns may result. Keep children, clothing, and furniture away. Keep gasoline and other liquids having flammable vapors away.

ATTENTION

L'appareil est chaud lorsqu'il fonctionne. Ne pas toucher l'appareil. Risque de brûlures graves. Surveiller les enfants. Garder les vêtements et les meubles loin de l'appareil. Garder l'essence ou autres liquides produisant des vapeurs inflammables loin de l'appareil.

Keep burner and control compartment clean. See Installation and Operating Instructions accompanying the appliance.

S'assurer que le brûleur et le compartiment des commandes sont propres. Voir les instructions d'installation et d'utilisation qui accompagnent l'appareil.

WARNING

Improper installation, adjustment, alteration, service, or maintenance can cause injury or property damage. Refer to the owner's information manual provided with this appliance. For assistance or additional information consult a qualified installer, service agency, or the gas supplier.

ADVERTISSEMENT

Une installation, un réglage, une modification, une réparation ou un entretien mal effectué peut causer des dommages matériels ou des blessures. Voir la notice de l'utilisateur qui accompagne l'appareil. Pour de l'aide ou des renseignements supplémentaires, consultez un installateur, un technicien agréé ou le fournisseur de gaz.

WARNING

If the vent system for this appliance is disconnected for purposes of cleaning or inspection, the vent system must be properly reinstalled and resealed prior to firing of this device.

ADVERTISSEMENT

Si le système d'évacuation de cet appareil est déconnecté à des fins de nettoyage ou d'inspection, le système d'évacuation doit être correctement scellé et remis en avant tir de cet appareil.

65-01-01452

WARNING

FOR VERTICAL VENT PIPE APPLICATIONS

Always maintain 1" clearance between vent pipe & combustibles.

FOR HORIZONTAL VENT PIPE APPLICATIONS

Always maintain 3" clearance from top of vent pipe and 1" clearance from side & bottom of vent pipe to combustibles

AVERTISSEMENT

INSTALLATIONS À CONDUIT D'ÉVACUATION VERTICAL

Toujours maintenir un dégagement de 25 mm (1 po) entre le conduit et les matières combustibles.

INSTALLATIONS À CONDUIT D'ÉVACUATION HORIZONTAL

Toujours maintenir un dégagement de 76 mm (3 po) sur le dessus du conduit et de 25 mm (1 po) sur les côtés et le dessous du conduit par rapport aux matières combustibles.

WARNING

This heater must be properly connected to venting system in accordance with the manufacturer's installation instructions. Operation of this heater when not connected to a properly installed and maintained venting system can result in carbon monoxide (CO) poisoning and possibly death.

ADVERTISSEMENT

Cet appareil de chauffage doit être correctement raccordé à un système d'évacuation conformément aux instructions d'installation du fabricant. Le fonctionnement de cet appareil s'il n'est pas raccordé à un système d'évacuation correctement installé et entretenu présente un danger d'intoxication au monoxyde de carbone (CO), voire de mort.

CAUTION

Do not operate the appliance with glass removed, cracked, or broken. Replacement of the panel(s) should be done by a licensed or qualified service person.

ATTENTION

Ne pas utiliser l'appareil si le panneau frontal en verre n'est pas en place, est craqué ou brisé. Confiez le remplacement du panneau à un technicien agréé.

65-01-01452

3.2.2 Planning the installation

This Mendota Fireplace must be installed and serviced by a qualified installer, service agency, or the gas supplier.

When planning on appliance installation, it is necessary to determine the following information before installing:

- Where the appliance is to be installed.
- The vent system configuration to be used.
- Gas supply piping.
- Electrical Wiring.
- Framing and finishing details.
- Hearth Protection Pad Requirements.
- Whether accessories such as a ceiling fan are desired.

3.2.2.1 Selecting Appliance Location

When selecting a location for your appliance, it is important to consider the required clearances to walls.

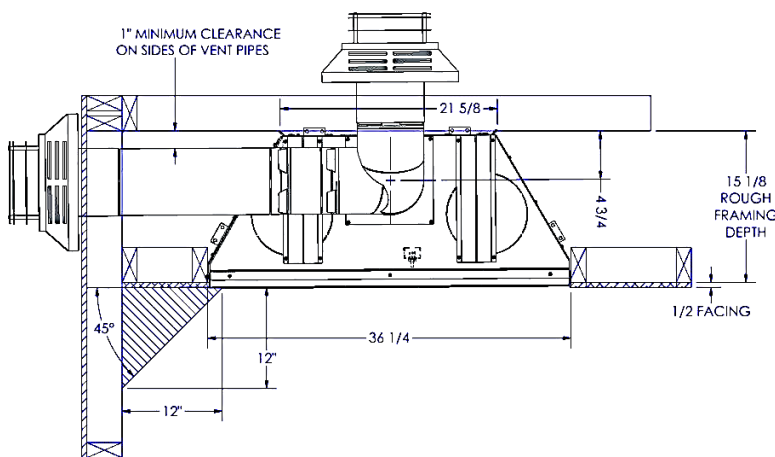

MINIMUM FRAMING DIMENSIONS

WIDTH = 36-1/4" HEIGHT = 31-7-16" DEPTH = 15-1/8"

Figure 3-2 FLAT WALL LOCATION

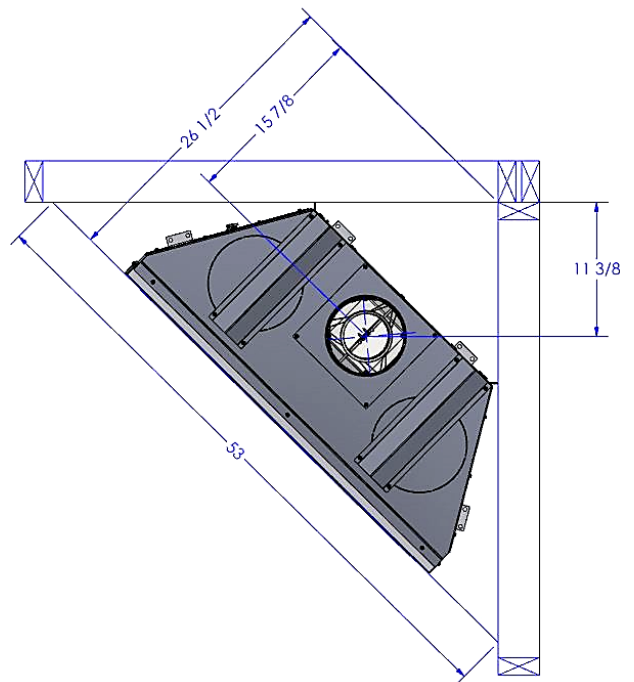

Figure 3-3 CORNER INSTALLATION

WARNING FIRE RISK- ODOR RISK

- Install appliance on hard metal or wood surfaces extending full width and depth of this fireplace.
- An R-1 Rated Hearth Protection Pad [1-1/2" Thick Maximum] and 12" deep is required unless this fireplace is elevated. For every 1" this fireplace is elevated, you may reduce the hearth pad depth by 2". If this fireplace is elevated 6" or higher no hearth protection pad is required.
- Do NOT install this fireplace directly on carpeting, vinyl or any combustible material other than wood. Construct chase to all clearance specifications in manual.
- Locate and install appliance to all clearance specifications in manual.

3.2.3 Dimensions and Technical Details

3.2.3.1 DXV35DT4 Fireplace Ratings Information

This Mendota Fireplace can be installed directly on top of a metal, masonry or wood structural surface.

ELECTRICAL REQUIREMENTS: 120 Volts AC, 1.5 Amps (minimum line voltage allowed 110 Volts AC) REQUIRED

GAS SUPPLY PRESSURE: NAT. GAS: 7" W.C. [5.0" W.C. MIN., 11" W.C. MAX.]

L.P. GAS: 11" W.C. [11" W.C. MIN., 13" W.C. MAX.]

LP GAS CONVERSION KIT: This Fireplace comes configured for use with Natural Gas. To convert the Fireplace for use with LP Gas, install: LP GAS CONVERSION KIT #HA-30-00507.

GAS INPUT RATES	High Fire	Low Fire
BTUH NAT. GAS	33,000	10,000
BTUH L.P. GAS	33,000	13,000

ORIFICE SIZES..... [0-2000ft (610 m)]: REAR BURNER: #44 NG [3/64" L.P.] – FRONT BURNER: #49 NG [3/64"]

P.4 FIREPLACE EFFICIENCY76.35%

FLUE VENTINGCOAXIAL RIGID- 4" DIAMETER EXHAUST &6-5/8" DIAMETER AIR INLET AND APPROVED VENT CAPS
All UL Listed Coaxial Rigid 4"X6-5/8" Vent pipe components and vent caps are approved for use. Do not mix components of different brands or series. Always use the same brand and series components throughout the entire vent system.

MINIMUM CLEARANCES TO COMBUSTIBLE CONSTRUCTION

UNIT TO FLOOR	0in. (0mm)	GLASS FRAME EDGE TO ADJACENT SIDEWALL	12in. (305 mm)
UNIT TO ENCLOSURE SIDEWALL	1/2in. (13mm)	VENT PIPE TOP TO COMBUSTIBLES	2in. (51mm)
UNIT TO ENCLOSURE BACK WALL	1/2in. (13mm)	VENT PIPE SIDES TO COMBUSTIBLES	1in. (25mm)
UNIT BOTTOM TO ENCLOSURE CEILING	53-3/8 in. (136 cm)	VENT PIPE BOTTOM TO COMBUSTIBLES	1in. (25mm)
UNIT BOTTOM TO ROOM CEILING	72 in. (1829 mm)		
DISTANCE TO 8" MANTLE ABOVE TOP CONVECTION AIR DISCHARGE OPENING	14 in. (356 mm)		

MINIMUM COMBUSTIBLE ROUGH FRAMING DIMENSIONS

WIDTH = 36-1/4" (920 mm) HEIGHT = 31-7/16" (799 mm) DEPTH = 15-1/8" (384 mm)

NET WEIGHT.....185 lbs. (Team Lift recommended)

BARRIER SCREEN: A barrier screen that has been certified for use with this Fireplace must be installed on the Fireplace when it is in use. The barrier screen will prevent accidental contact with the glass door face, which could result in a severe burn.

SAFETY: AGA certified, electronic ignition IPI system activated with thermostatic remote control.

CERTIFIED TO: ANSI Z21.88-2019(R2024)/ CSA2.33-2019(R2024)

This Mendota Gas Fireplace has been tested and certified by:
Intertek Testing Services, 8431 Murphy Drive, Middleton, WI 53562\
ICBO#AA647-4

3.2.3.2 Fireplace Features

EXTERNAL DIMENSIONS: 36-1/4 Wide X 31-7/16" High X 15-5/8" Deep

MINIMUM FRAMING DIMENSIONS: 36-1/4" WIDE x 31-7/16" HIGH X 15-1/8" DEEP

GLASS SIZE: NeoCeram Glass with non-reflective coating. Visible Glass measures 28-3/8" X 16-1/16".

MANTEL ALLOWANCE: 8" Deep Mantel at 14" Above Top Convection Opening (41" up from base of Unit)

VENT SYSTEM ALLOWANCE: Top Vent Only. 12" Vertical Minimum with 6" max horizontal. 55 feet Vertical Maximum. 4" exhaust and 6-5/8" combustion air intake coaxial vent pipe required. 12' maximum horizontal run allowed with 4' minimum vertical starter section.

VENT DAMPER ADJUSTMENT AVAILABLE: There is one exhaust vent damper included in this unit and located in the top convection chamber at the center.

CONTROLS: IPI Electronic Ignition System with AC Primary Power and DC Backup Power. Accent light and Blowers operate on AC Power only. Thermostatic Remote-Control Transmitter with Smart Thermostat Mode.

BLOWER SYSTEM: 190 CFM Dual Blower System. 120VAC, 2Amps. Dedicated Hot Power only. No switches, Fan Speed Controls or Light Dimmers are allowed in same circuit.

Accent Light System: Accent Light System Included. Light can be turned on or off or dimmed using dimmer mounted behind lower grill. Accent Light can also be turned on or off using Remote Control Transmitter.

BURNER SYSTEM: Dual 304 Stainless Steel Tubular burners.

BURNER AIR SHUTTER SYSTEMS: Externally controllable Rear Burner air shutter and Internal rotary Front Burner air shutter.

LOG SET: 9-piece, Premium Definition Log Set with Extreme glow and realism ember bed.

REFRACTORY PANELS: High Detail Red Clinker Fiber Brick Panels included. Brick Panels required for operation.

NATURAL GAS INFORMATION: Factory equipped for Natural Gas. 4.5"WC Minimum inlet pressure required. For NG applications, Front Burner Orifice Size is #49 and the Rear Burner Orifice Size is #44.

LPG INFORMATION: LP conversion kit #HA-30-00507 is required. 12"WC Minimum inlet pressure required. For the DXV35 DT4 LPG application, both front and rear burner orifices are to be drill size 3/64". For higher altitude, adjustment to orifice size may be necessary.

3.2.3.3 Fireplace Dimensions and Clearances

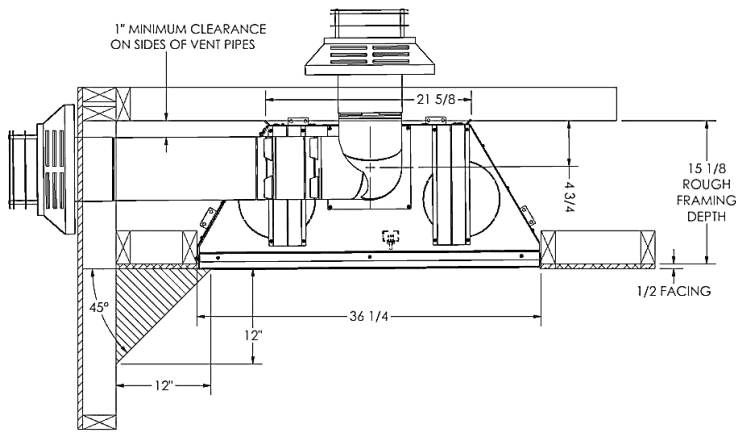

MINIMUM FRAMING DIMENSIONS

WIDTH = 36-1/4" HEIGHT = 31-7-16" DEPTH = 15-1/8"

Figure 3-4

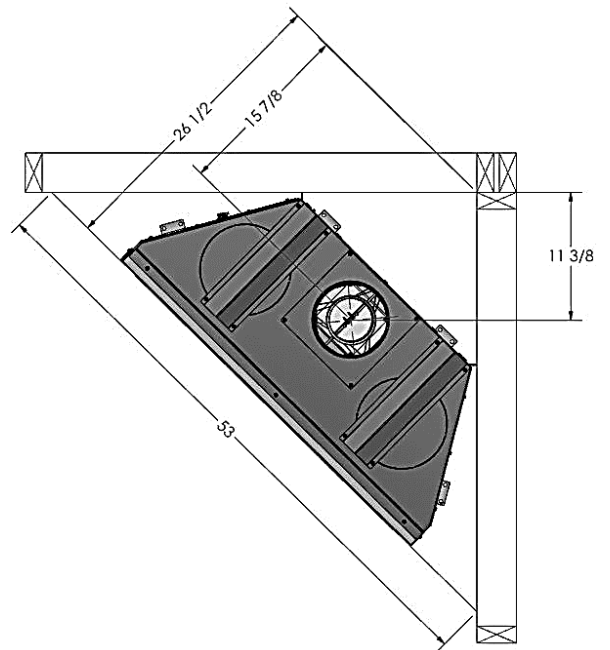

Figure 3-5

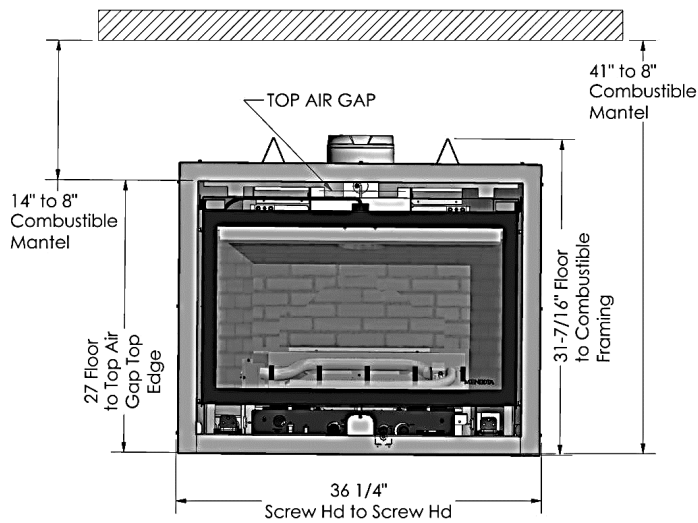

Figure 3-6

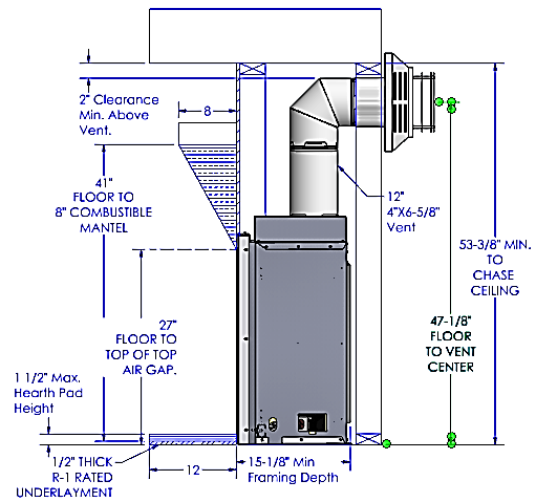

Figure 3-7

A wall, perpendicular and in front of this appliance's glass door face must be at least 12" away from the side edges of the glass frame.

A wall at a 45° angle to the front face and starting at the Side Edge of the Front Face of this appliance is allowed.

Projections behind this 45° angle edge (shaded area) are allowed.

Caution: The distance from floor level to the centerline of the vent cap is based on Simpson DuraVent GS components. If using vent components of another brand, do not assume that the measurement given here is applicable. Verify the distance to the centerline of vent cap by measuring the components you are using.

Note: For every 1" this fireplace is raised off the floor, the non-combustible hearth protection pad may be reduced by 2". If this fireplace is raised more than 6" off the floor, no hearth protection pad is required. See [Chapter 3.2.4.1 Hearth Pad Requirement](#)

A non-combustible hearth protector with a thermal insulation rating of R-1 is required when installing this fireplace directly on the floor and must extend a minimum of 12" in front of this fireplace.

For every 1" the fireplace is raised off the floor, the depth of the required R-1 hearth protector may be reduced by 2". If the fireplace is raised off the floor 6" or more, no R-1 hearth protector is required for fire protection.

Raising the fireplace only removes the requirement for a R-1 rated hearth protector. The floor in front of the fireplace will still get hot up to 200 °F. The higher the fireplace is raised the lower the temperatures on the floor will be. Materials used on the floor in front of the fireplace must be appropriate for elevated temperatures.

Flooring materials such as carpet, vinyl and laminated floors may warp or be damaged if installed in front of this fireplace. If these materials are used it is recommended that the fireplace is raised at least 12" above the floor.

Mendota does not guarantee any materials used around the fireplace. Mendota disclaims any and all liability for any damage to finishing materials including warping, discoloring, cracking, peeling or flaking. This also includes any off-gassing or unpleasant smells from materials when they are heated.

3.2.3.3.1 Hearth Pad Materials

A hearth pad with an R-Value of at least 1 is required unless the fireplace is raised off the floor 6" or more. A list of common finishing materials and their R-Values is included in the "R-Values of Common Finishing Materials" section of this manual. Many finishing materials have a low R-Value. For example, 1" thick granite has a R-Value of only .05. When building a conforming hearth pad it may be necessary to use an insulating underlayment board with a high R-Value. A list of some possible underlayment boards is given below. These boards are not structural they can be easily dented and damaged. They must only be used as an insulator under other non-combustible finishing material.

The fireplace can sit on a wood or cement floor. An R-1 rating is not required under the fireplace.

R-Values of Hearth Pad Boards

<i>Material</i>	<i>Thickness</i>	<i>R-Value</i>	<i>Application</i>
Mineral Fiber Board (Micore 160, 300, SB)	1/2"	1.27 – 1.47	Hearth Pad Insulator
Cearmic Board (Rescor 360)	1/2"	1.11	Hearth Pad Insulator
Cearmic Board (Fiberfrax Duraboard LD)	1/2"	1.10	Hearth Pad Insulator

and [Chapter 3.2.5.1 Hearth Pad Temperatures](#).

3.2.3.4 Rough Framing Dimensions

The rough framing dimensions given are the minimum allowed framing dimensions. Be sure when planning the framing of the unit that adequate paths to route the gas and electrical are available on both sides of the unit.

SPECIAL FRAMING NOTE:

If the fireplace is to be recessed in a cavity deeper than 15-1/8", all framing and finishing materials protruding past the front face of this fireplace must be of the NON-COMBUSTIBLE variety.

Minimum Required Rough Framing Dimensions		
	DESCRIPTION	DIMENSION (INCHES)
A	WIDTH	36-1/4"
B	HEIGHT	31-7/16"
C	DEPTH	15-1/8"
E	FINISH MATERIAL THICKNESS	Varies
F	UNIT BASE TO ENCLOSURE CEILING	53-5/8"
G	GLASS FRAME EDGE TO SIDE WALL	12"
H	UNIT BASE TO 8" MANTEL	41"

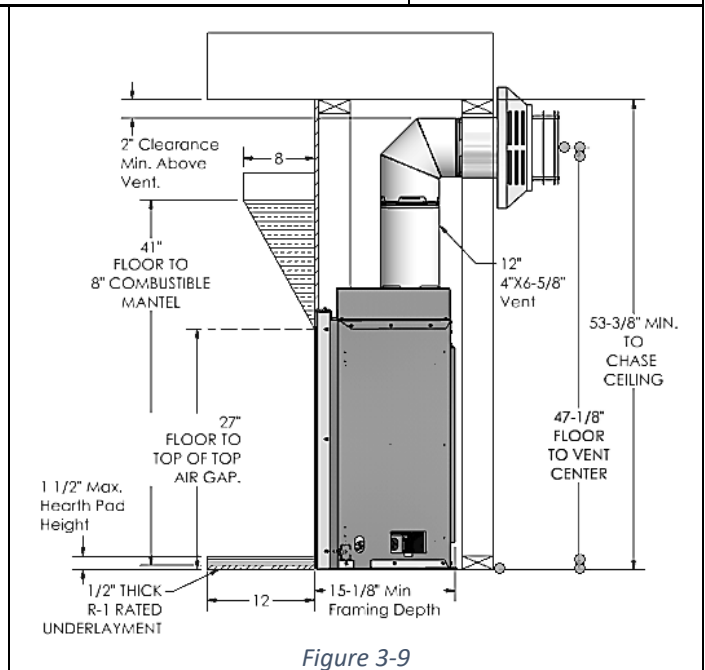
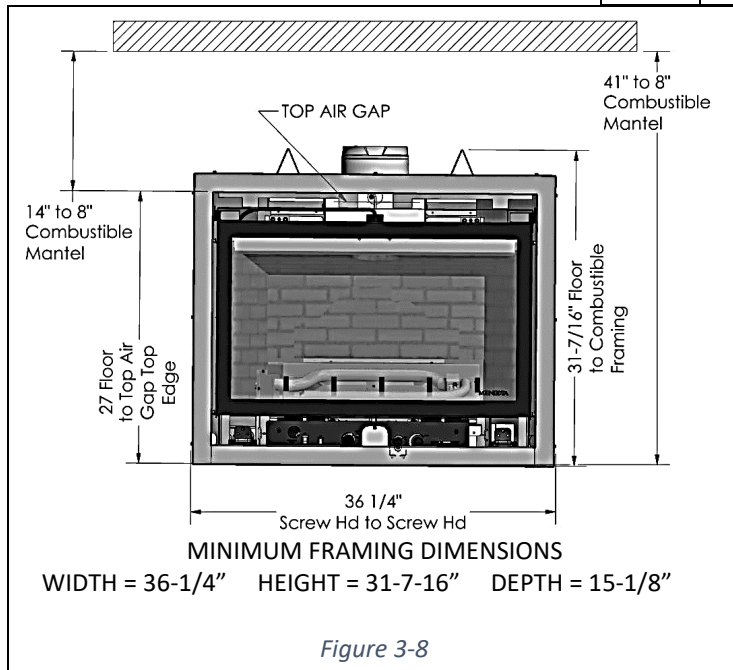

If the mantel is constructed of non combustible materials, it may be placed at any distance above the top air gap.

Caution: Materials made of porous stones or sedimentary rocks may crack due to expansion of the material if placed around this appliance. Use suitable materials which are crack resistant and high temperature resistant.

3.2.3.5 Constructing the Appliance Chase

A chase is a vertical box-like structure built to enclose this fireplace and its vent system. Vertical vents that run on the outside of a building may be, but are not required to be, installed inside a chase.

Construction of the chase may vary with the type of building. These instructions are not substitutes for the requirements of local building codes. Local building codes **MUST** be adhered to.

Chases should be constructed in the manner of all outside walls of the home to prevent cold air drafting problems. The chase should not break the outside building envelope in any manner.

Wall, ceiling, base plate and cantilever floor of the chase should be insulated. Vapor and air infiltration barriers should be installed in the chase as per regional codes for the rest of the home. Additionally, in regions where cold air infiltration may be an issue, the inside surfaces of the chase may be sheet rocked and taped for maximum air tightness.

To further prevent drafts, the fire stops should be caulked with high temperature caulk to seal the gaps. Gas line holes and other openings should be caulked with high temp caulk or stuffed with unfaced insulation. If the appliance is being installed on a cement slab, a layer of plywood may be placed underneath this fireplace to prevent conducting cold up into the room

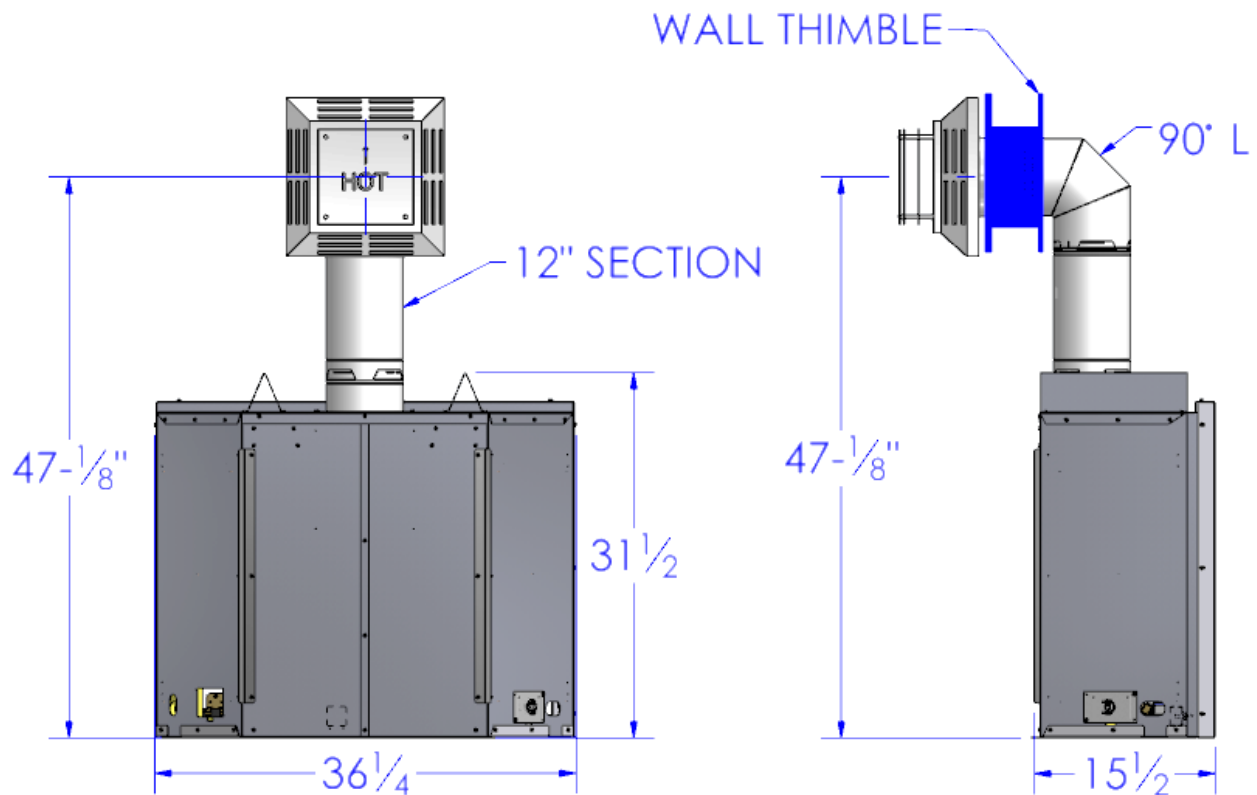
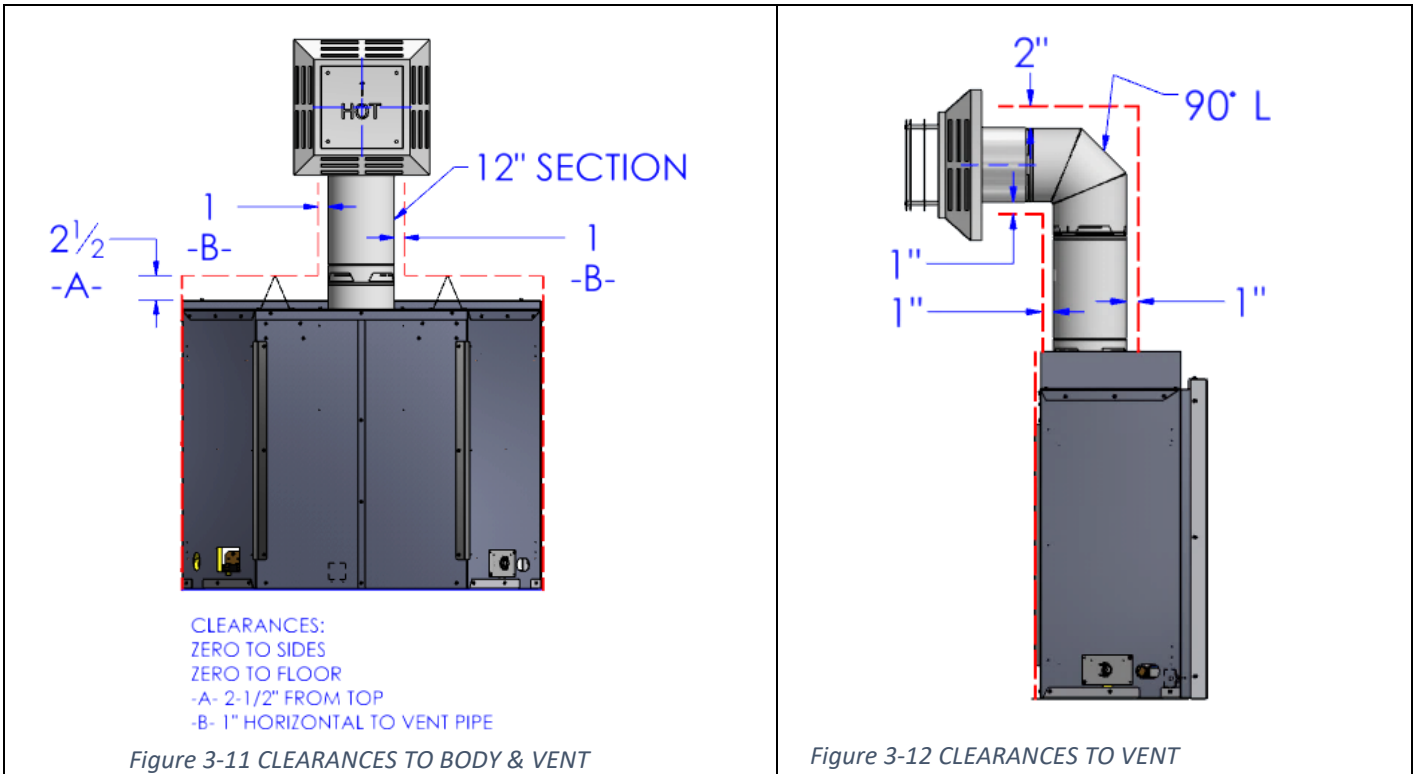

Figure 3-10 Floor to Vent Cap Center Dimension

3.2.4 Clearance Requirements

3.2.4.1 Clearance from Appliance Body and Vent



The required clearances are depicted in these diagrams.

1. Minimum Clearance from fireplace body sides to combustibles is zero.
2. Minimum Clearance from fireplace top surface to combustibles is 2-1/2" or zero from top edge of top triangle standoffs.
3. Minimum Clearance from vertical vent pipe sides to combustibles is 1".
4. Minimum Clearance below horizontal vent pipe or components is 1".
5. Minimum Clearance above elbows and horizontal vent pipe and components is 2".

3.2.4.1 Hearth Pad Requirement

A non-combustible hearth protector with a thermal insulation rating of R-1 is required when installing this fireplace directly on the floor and must extend a minimum of 12" in front of this fireplace.

For every 1" the fireplace is raised off the floor, the depth of the required R-1 hearth protector may be reduced by 2". If the fireplace is raised off the floor 6" or more, no R-1 hearth protector is required for fire protection.

Raising the fireplace only removes the requirement for a R-1 rated hearth protector. The floor in front of the fireplace will still get hot up to 200 °F. The higher the fireplace is raised the lower the temperatures on the floor will be. Materials used on the floor in front of the fireplace must be appropriate for elevated temperatures.

Flooring materials such as carpet, vinyl and laminated floors may warp or be damaged if installed in front of this fireplace. If these materials are used it is recommended that the fireplace is raised at least 12" above the floor.

Mendota does not guarantee any materials used around the fireplace. Mendota disclaims any and all liability for any damage to finishing materials including warping, discoloring, cracking, peeling or flaking. This also includes any off-gassing or unpleasant smells from materials when they are heated.

3.2.4.1.1 Hearth Pad Materials

A hearth pad with an R-Value of at least 1 is required unless the fireplace is raised off the floor 6" or more. A list of common finishing materials and their R-Values is included in the "R-Values of Common Finishing Materials" section of this manual. Many finishing materials have a low R-Value. For example, 1" thick granite has a R-Value of only .05. When building a conforming hearth pad it may be necessary to use an insulating underlayment board with a high R-Value. A list of some possible underlayment boards is given below. These boards are not structural they can be easily dented and damaged. They must only be used as an insulator under other non-combustible finishing material.

The fireplace can sit on a wood or cement floor. An R-1 rating is not required under the fireplace.

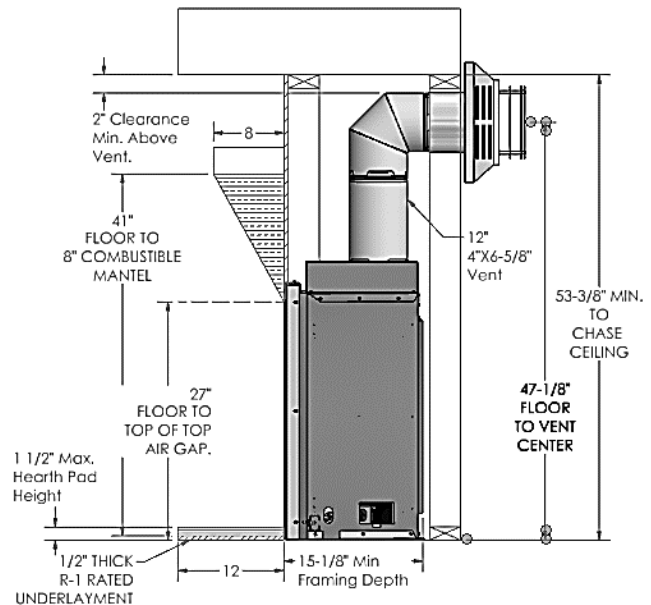
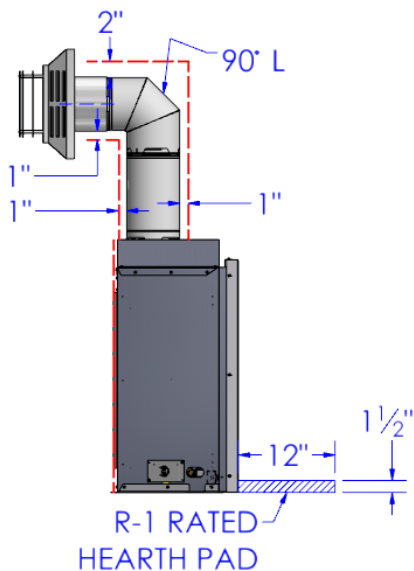

R-Values of Hearth Pad Boards

<i>Material</i>	<i>Thickness</i>	<i>R-Value</i>	<i>Application</i>
Mineral Fiber Board (Micore 160, 300, SB)	1/2"	1.27 – 1.47	Hearth Pad Insulator
Cearmic Board (Rescor 360)	1/2"	1.11	Hearth Pad Insulator
Cearmic Board (Fiberfrax Duraboard LD)	1/2"	1.10	Hearth Pad Insulator

3.2.4.2 Clearances to Combustible Mantels

An 8" combustible mantel may be installed at a minimum of 14" above the top of the heat outlet (41" up from the floor level of this Fireplace). Non-combustible (marble, brick, stone, metal etc.) mantels can be installed at any desired height above the top convection air opening. Any pre-existing combustible mantel must fall within the approved mantel profile chart.

WARNING: Make proper use of this chart. Do not compromise the specifications contained in this chart.

Failure to adhere to proper clearances required to combustibles may cause spontaneous combustion of the mantel and may result in a fire causing property damage, personal injury or loss of life.

NOTE: For mantels that protrude more than 8 inches from the front surface of the fireplace use a rise and run of (7:4) to calculate the required height to the mantel. **EXAMPLE:** You have a 12" mantel. To calculate the height above the convection air opening the equation would be: $12" \times (7/4) = 21"$ above the convection air opening. **DO NOT** deviate from this minimum clearance requirement. Doing so can lead to a severe fire hazard.

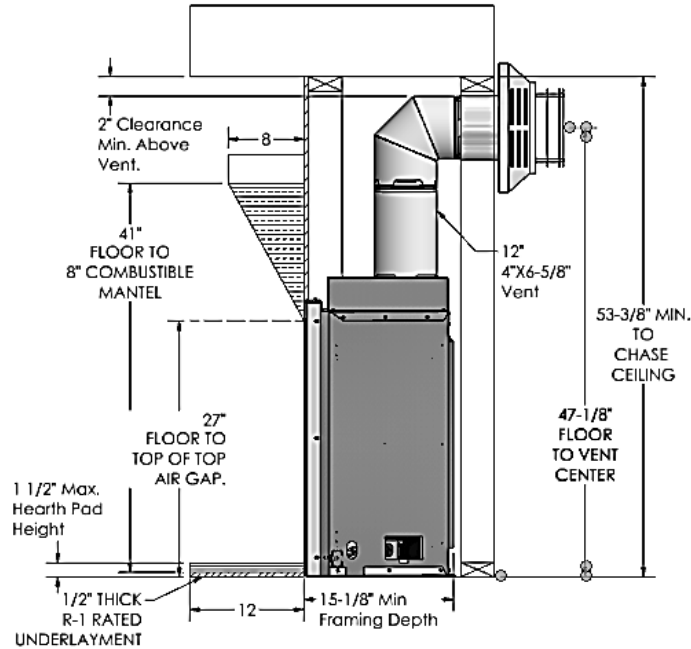

Note: The distance from the Floor Level of this Fireplace to the Top Air Gap is 27".

Figure 3-13 Mantel Clearances

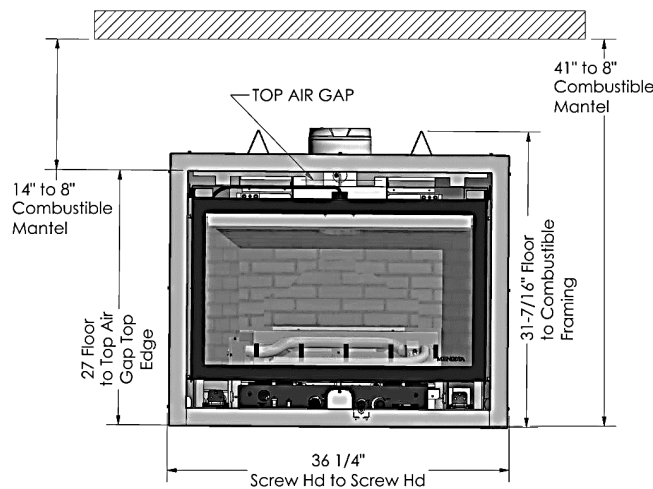

Figure 3-14 Mantel Clearances

3.2.5 Normal Surface Temperatures

WARNING: The supplied barrier screen must be installed, always, when this fireplace is in operation. Do not place any object directly in front (within 60" from barrier screen surface) or directly above (on the front edge of the mantel). This is a heating appliance. Areas directly in front and above this appliance will be very hot and can damage most household objects if placed too close. Keep Furniture pieces at least 60" away in front of the barrier screen surface.

HINT: To greatly reduce surface temperatures surrounding this Fireplace during operation, Mendota recommends operating the integrated convection air blowers which aid in cooling all surrounding surfaces.

Mendota Fireplaces comply with ANSI Z21.88 Standards for maximum surface temperatures (ambient plus 117°F) on exposed "combustible" surfaces adjacent to the Fireplace.

Be aware that surfaces in front of, above and adjacent to this heater appliance can be too hot to touch. As long as all required clearances to combustibles are met and the required finishing materials are used, this appliance will perform safely. Note that the exposed surfaces immediately surrounding the Fireplace can have surface temperatures that are too hot to touch. This level of surface temperature is considered normal and does not indicate any hazardous situation.

3.2.5.1 Hearth Pad Temperatures

New hearth protection pads installed are required to have a thermal insulation value of R-1.

The top exposed surface of the noncombustible hearth pads can reach a temperature that is too hot to touch.

As high as 250°F This is considered normal.

3.2.5.2 Surround Face Temperatures

Areas of the breastplate directly above the top convection air gap of this Fireplace can be very hot (too hot to touch) and is deemed normal.

3.2.5.3 Mantel Temperatures

Mendota Fireplaces comply with ANSI Z21.88/CSA2.33 standards for maximum surface temperatures on exposed "combustible" surfaces adjacent to the Fireplace. Be aware that surface in front of, above and adjacent to this heater appliance can be too hot to touch. As long as all required clearances to combustibles are met and the required finishing materials are used, this appliance will perform safely.

Note that the exposed surfaces immediately surrounding the Fireplace can have a surface

temperature too hot to touch. This level of surface temperatures is considered normal and does not indicate any hazardous situation.

WARNING: Surfaces surrounding this Fireplace can be very hot to the touch during operation. Carefully supervise children and pets while this Fireplace is operating.

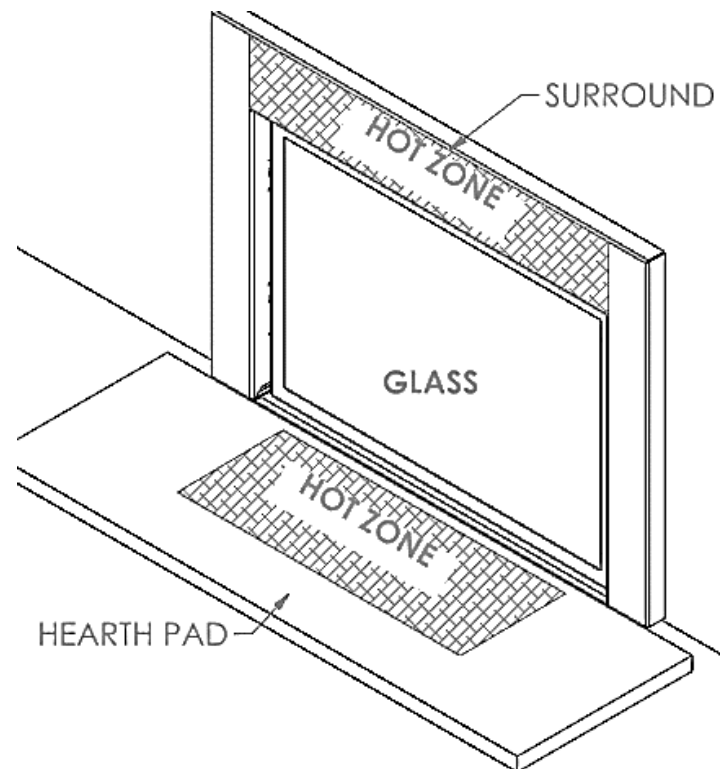

Figure 3-16 Hot Zones

3.2.1 Suitable Mantel, Facing & Hearth Pad Materials

Materials used in areas designated as non-combustible must be rated as non-combustible per NFPA 220 Standard on Types of Building Construction, or reported as passing ASTM E 136, Standard Test Method for Behavior of Materials in a Vertical Tube Furnace at 750 Degrees C.

WARNING: Common Finishing Materials Not Approved for use.

Paper faced gypsum board (drywall) including Type X Fire Rated board is not a non-combustible material. These boards are not approved for use in the non-combustible zone of the fireplace.

WonderBoard brand boards are commonly used as a backerboard for tile. WonderBoard backerboard is not a non-combustible material and is not approved for use in the non-combustible zone of the fireplace. In addition, WonderBoard off-gasses when heated and should not be used anywhere near the fireplace.

Mendota does not guarantee any materials used around the fireplace. Mendota disclaims any and all liability for any damage to finishing materials including warping, discoloring, cracking, peeling or flaking. This also includes any off-gassing or unpleasant smells from materials when they are heated.

3.2.1.1 R-Values of Common Finishing Materials

R-Values of Hearth Pad Boards			
<i>Material</i>	<i>Thickness</i>	<i>R-Value</i>	<i>Application</i>
Mineral Fiber Board (Micore 160, 300, SB)	1/2"	1.2 – 1.4	Only approved for use as an insulator under other non-combustible finishing material for a hearth pad. Do not use on the face of a fireplace or wall.
Cearmic Board (Rescor 360)	1/2"	1.11	
Cearmic Board (Fiberfrax Duraboard LD)	1/2"	1.10	

R-Values of Common Finishing Materials			
<i>Material</i>	<i>Thickness</i>	<i>R-Value</i>	<i>Application</i>
SkamoEnclosure Board	1"	0.410	Best option for a smooth wall finish. Least chance of cracking from heat.
Promat Promafour	1"	0.410	
Cement Board (Hardibacker 500)	1/2"	0.200	Best used as a backer board for tile or natural stone installations. Not recommended as a smooth wall finish unless used with a Cool Wall heat transfer system.
Cement Board (Hardibacker)	1/4"	0.130	
Common Brick	2-1/4"	0.450	Common non-combustible materials used around a fireplace. Can be used on the wall or hearth pad. Install these materials per the recommendations in the following sections.
Common Brick	4"	0.800	
Thinset Mortar	1/4"	0.100	
Concrete (150 lbs/Cubic Foot)	1"	0.07	
Ceramic Tile	1/4"	0.25	
Flagstone	1"	0.079	
Granite	1"	0.05	
Limestone	1"	0.08	
Marble	1"	0.08	
Sandstone	1"	0.079	
Slate	1"	0.100	

3.2.1.2 Smooth Wall

When creating a smooth wall finish around the fireplace the correct materials and installation method must be followed to

minimize the risk of cracks forming on the wall. Promat Promafour and SkamoEnclosure Board are two of the best options when creating a smooth wall finish. These boards have been designed to create a smooth wall finish around a fireplace. These materials can be hard to source and may not be available in all areas.

Another recommended option when creating a smooth wall look is to utilize the Cool Wall heat transfer system. The cool wall system keeps the wall above the fireplace cooler reducing the risk of the finishing material cracking. When the cool wall system is used Hardibacker 500 is recommended material to use. This material is available at most hardware stores.

For all smooth wall installations, the wall material should not be screwed to the metal face of the fireplace. The wall material should be attached to the wood framing around the fireplace and floated over the face of the fireplace. Size and install the boards so there are no seams above the fireplace. This will reduce the risk of the wall cracking as the fireplace expands and contracts during heating and cooling.

3.2.1.3 Ceramic or Porcelain Tile

Use of ceramic or porcelain tiles as facing materials around a Mendota fireplace is approved. If selecting a mosaic tile where tiles are held together with a webbing, ensure the webbing is a non-combustible material like fiberglass. Also ensure that the tiles are not attached to the webbing with a glue or epoxy that will off gas and smell when heated.

Use caution when selecting tile adhesives. Avoid polymer-modified mortars. These mortars will off-gas and smell when heated. Use unmodified dry-set mortar or hi-temp RTV Silicone to attach ceramic glazed tiles as facing in hot areas around this fireplace. If using hi-temp RTV silicone, allow a minimum 48 hours cure time. A non-combustible backer board must be used when installing tile in a non-combustible zone around the fireplace.

3.2.1.4 Marble, Granite and Natural Stones

Marble, granite and other natural stone products are approved for use as mantel, facing and hearth pad materials with the following limitations and understanding of these cautionary statements:

Never use a one-piece marble, granite or natural stone that is water jet or mechanically cut in a U-shape as facing material to cover the sides and top areas around this product. Doing so can lead to crack formation at the inner corners of the U shape due to thermal expansion.



Figure 3-17 Three Piece Stone

Most marble slabs and marble tiles contain a polyester resin coating while most granite slabs and granite tiles contain epoxy resin coatings. The polyester resin coatings and the epoxy resin coatings provide structural strength to the stone slabs and prevent cracking, chipping and breakage during shipping and handling. These coatings also provide a glossy or satin surface finish and help seal the stone surface.

The polyester resin used on marble slabs can discolor when exposed to temperatures greater than 150°F and will structurally fail at temperatures above 230°F. The epoxy resin coating used on granite slabs are resistant to discoloring and structural failures up to 350°F. Mendota does not assume any liability for discoloring, flaking or cracking of marble or granite.

Temperatures on facings around Mendota fireplaces can reach 350°F directly outside the top convection air gap. These temperatures will discolor polyester resin coated marble facings and can cause the polyester resin coating to fail near the top convection air gap.

Mendota cannot guarantee suitability of use of any marble slabs or tiles that have a polyester resin coating applied to it and cannot guarantee against discoloration or structural failure of marble or polished stone facings that have a polyester resin coating. Consult with your local stone supplier.

Prior to use of any marble, granite or polished stone facing material, especially white colored ones, run heat exposure tests on a sample piece. Expose sample pieces to temperatures between 275°F and 350°F for a period of eight hours. Compare the heat exposed sample to a control unheated piece and judge for color changes. Do not use if any color changes are evident.

Mendota recommends the use of honed bare marble and bare stone facing materials or honed bare granite and epoxy resin coated granite only.

Mendota cautions that due to natural structural defects that can exist within marble and stone pieces, cracking and/or flaking of the marble or stone is possible and must be considered prior to selection and application around Mendota fireplaces. Mendota further cautions that proper adhesives be used to attach stone facings. Pay attention to the potential of off gassing of chemical vapors from mastic and other adhesives. Improper selection can lead to emission of chemicals with unwanted smells.

3.2.1.5 Suitable Paints and Sealant Materials

3.2.1.5.1 Paint Types Approved for Use

Industrial Acrylic Paints, Alkyd based Paints. When selecting paint for applications on facings, mantels, corbels or floors within 2' in front of a fireplace raised 6" or higher, avoid off the shelf paints which may have modifier additives used to increase "hiding" ability, accelerate drying times and curing times. Consult with a reputable paints and sealants supplier and acquire industrial acrylic paints or alkyd-based paints.

3.2.1.5.2 Sealants Type Approved for Use

Heat resistant polyurethane sealants which are not damaged by prolonged exposure to raised temperatures. Many are flame resistant, meaning that they resist ignition when exposed to high temperatures and can insulate the substrate and delay damage to it. When selecting polyurethane for applications on facings, mantels, corbels or floors within 3' in front of or above a fireplace, avoid off the shelf urethane sealants which may have modifier additives used to accelerate drying times and curing times. Consult with a reputable paints and sealants supplier and acquire heat resistant polyurethane sealants.

3.2.1.5.3 Wood Application Cautions

If wood used around or in front of the fireplace has been chemically cleaned or bleached prior to staining or painting, it is of the utmost importance to make certain that the cleaner or bleach does not remain in the wood substrate under the final paint or sealant applied. If any cleaner or bleach remain within the wood structure, application of heat from the fireplace, even low-level heat, will cause the cleaner or bleach compounds to expand or evaporate causing separation of the paint or sealant from the wood surface and may cause peeling or bubbling of the paint or sealant.

Moisture content of the wood substrate is also of critical importance. High moisture content wood when heated will yield evaporation of the moisture and hydraulic pressure under the paint or sealants which can lead to peeling or bubbling. Always select the lowest moisture content wood substrate.

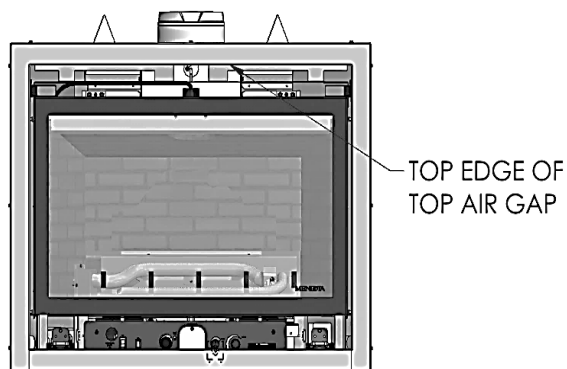

Figure 3-18 Top Air Gap

3.2.2 Recommendations for Television Installation

Note: The model depicted in the images is a representation of a Mendota Hearth fireplace. These recommendations apply to all Mendota Hearth Fireplaces.

When planning to install a television or other heat sensitive product above your fireplace, there are some points to consider.

Many television manufacturers specify in their installation instructions that the television must not be installed near or above a heat source. The decision to install a television near or above a Mendota fireplace rests solely on the consumer. It is the consumers responsibility to satisfy television specifications and insure the television will not exceed maximum operation temperatures. Mendota Hearth will not be held liable for any adverse effects on a television or other products located near to a Mendota Hearth fireplace.

The drawings below show recommendations that may be used as a guide for those consumers that decide to locate a television above a Mendota Hearth fireplace. These recommendations have been found to reduce the heat impact to a television when installed above a Mendota Hearth fireplace.

3.2.2.1 Recommendation 1: Add a mantel

Add a mantel above the fireplace. The mantel shall be at least 2 inches deeper than the depth of the television, and at least as wide as the television. The mantel shall be mounted so that its top surface is a minimum of 18 inches above the top air gap of the fireplace.

Attention: If the mantel is constructed of combustible materials, make certain that the entire mantel meets the clearances to combustible mantel requirements.

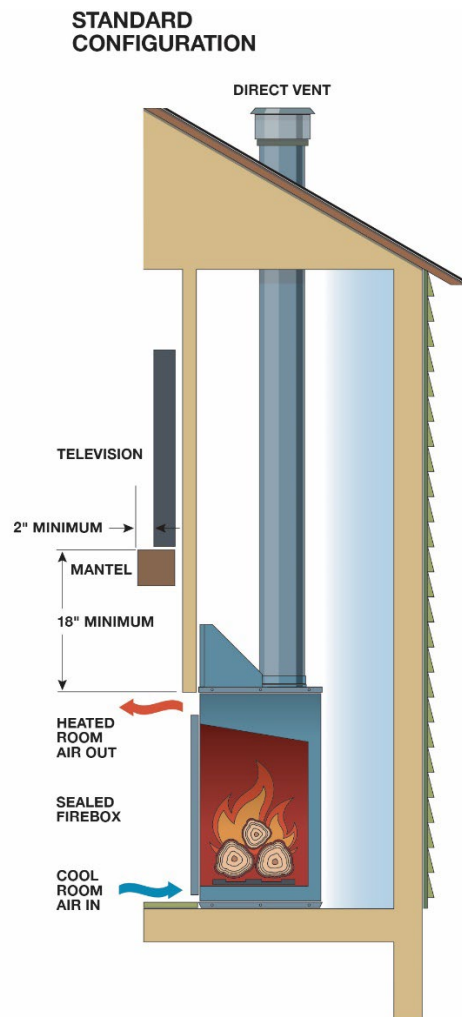

3.2.2.2 Recommendation 2: Create a recessed cavity

Frame a recessed cavity above the fireplace. The cavity shall be at least 6 inches taller and 6 inches wider than the television. The cavity's bottom surface must be a minimum of 24 inches above the top air gap of this fireplace. The cavity must be deep enough for the television to be recessed at least 2 inches in from the wall.

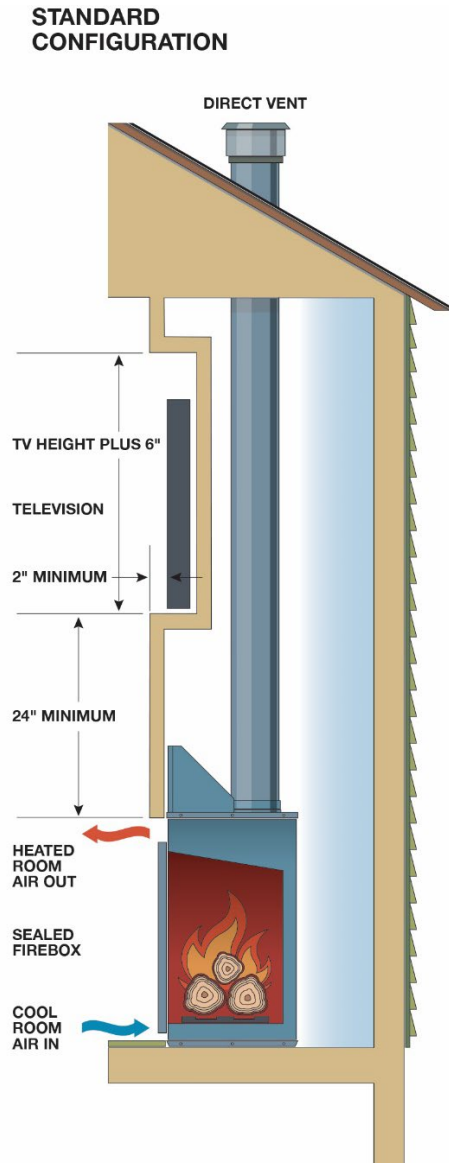

3.2.2.3 Recommendation 3: Install a heat transfer system

Mendota Hearth offers three heat transfer systems that take heat from the fireplace and redirect it to another area. When used correctly these heat transfer systems can make it possible to mount a television above the fireplace without installing a mantel or creating a recessed cavity.

Note: Heat transfer systems are not available for use on M27 model fireplaces.

WARNING: The convection fans on the fireplace must be turned off to insure the heat from the fireplace is redirected through the heat transfer system. Turning the convection fans on will force heated air out the front of the fireplace, heating the surrounding area.

- On fireplaces with a millivolt system: DXV35 Timberfire, DXV42, DXV60, M50 the convection fans must be disconnected from power to insure they cannot be turned on.
- On fireplaces with electronic ignition system that come with a PF2 remote the convection fans function must be programmed out of the remote. This will ensure that the convection fans cannot be turned on. Follow the directions below to remove the convection fans function from the remote.

1. Remove a battery from the remote.
2. Hold down both the ON/OFF key and MODE key and reinstall the battery.
3. Continue to hold the ON/OFF key. Release the MODE key. Press the MODE key once to highlight the convection fan function. *

4. While still holding the ON/OFF key press the DOWN ARROW key. The display will change from "Set" to "Clr" to indicate that the convection fan function has been disabled.
5. Release the ON/OFF key.

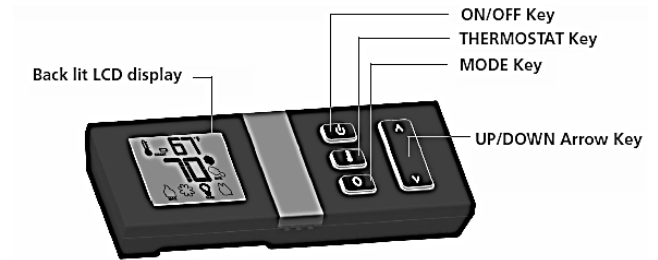

3.2.2.3.1 Mendota Cool Wall

The Mendota Cool Wall system uses natural convection to take heat off the wall directly above the fireplace and redirects it up and away from surrounding areas. Testing has shown that when using a Cool Wall system, temperatures above the fireplace are reduced making it possible to mount a television 15" above the fireplace's top air gap.

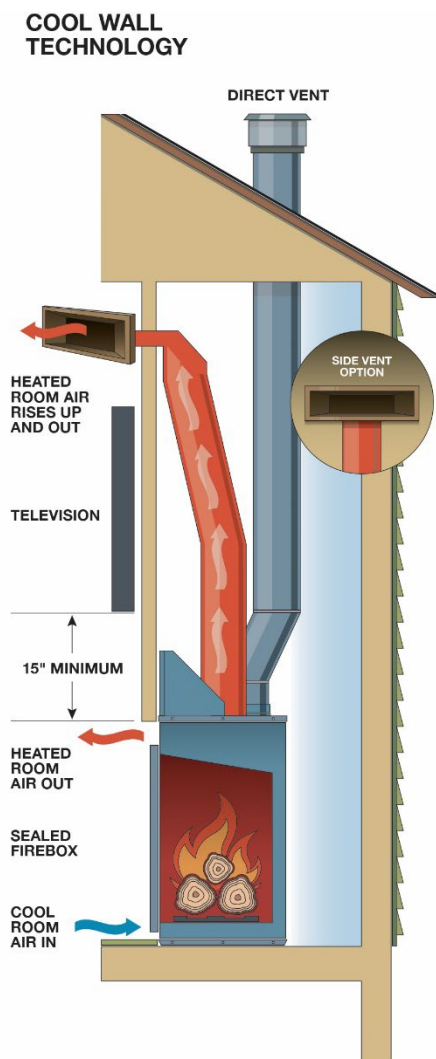

3.2.2.3.2 Versiheat

The Versiheat system uses a fan to redirect heat from the fireplace to an alternate room in the home.

WARNING: To reduce temperatures above the fireplace for mounting a television the Versiheat system must always be on when the fireplace is in operation. Because the Versiheat system must be running to reduce temperatures the fireplace cannot be operated during a power outage.

Testing has shown that when using two Versiheat systems temperatures above the fireplace are reduced making it possible to mount a television 15" above the fireplace's top air gap.

VERSIHEAT TECHNOLOGY

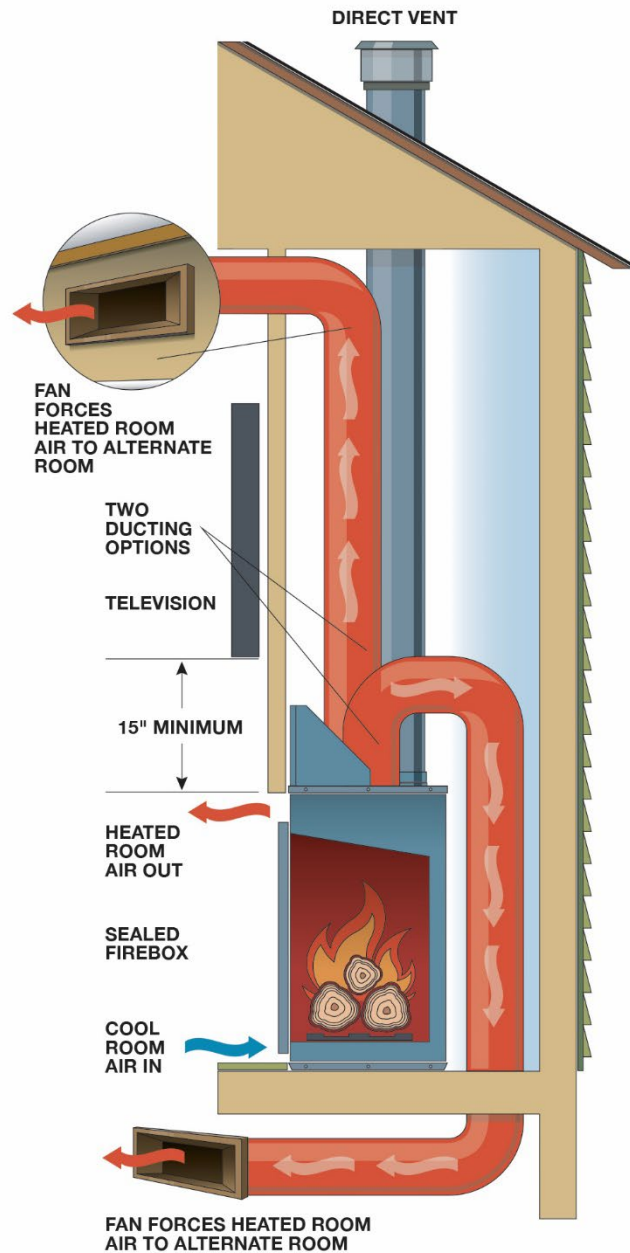

3.2.2.3.3 FlexHeat

The FlexHeat system uses two inline fans to redirect heat from the fireplace outside the home or to an alternate room in the home.

WARNING: To reduce temperatures above the fireplace for mounting a television the FlexHeat system must always be on when the fireplace is in operation. Because the FlexHeat system must be running to reduce temperatures the fireplace cannot be operated during a power outage.

Testing has shown that when using the FlexHeat system temperatures above the fireplace are reduced making it possible to mount a television 12" above the fireplace's top air gap.

FLEXHEAT TECHNOLOGY

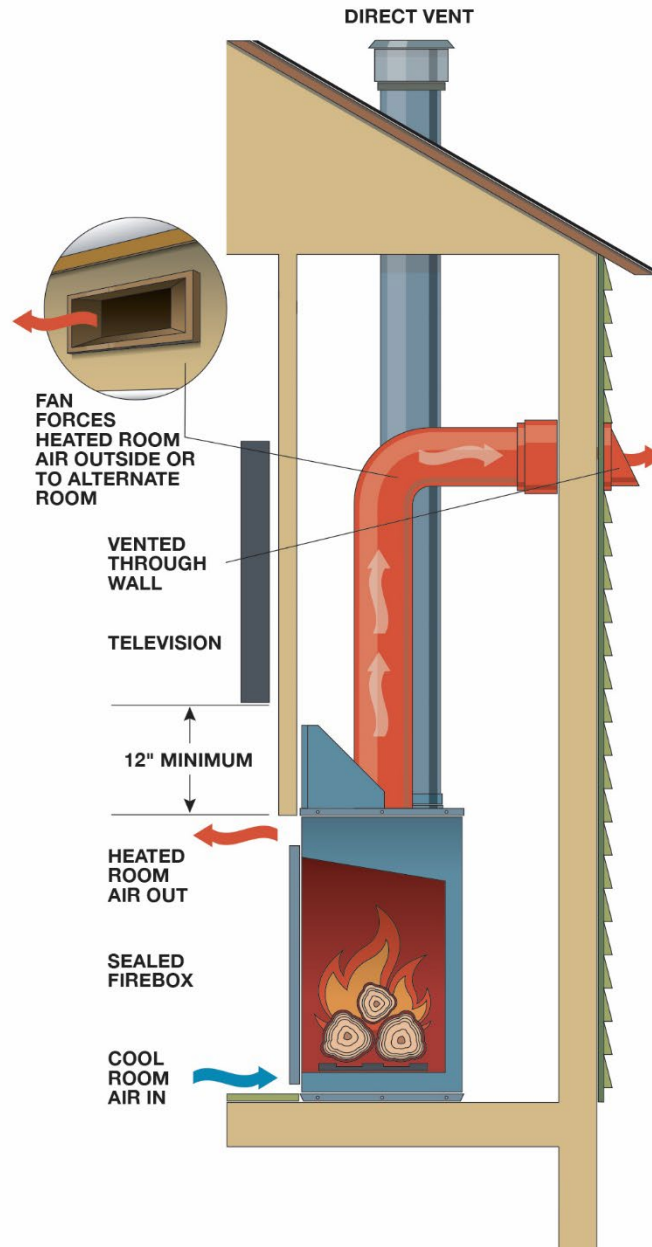

3.2.3 Venting

The DXV35DT4 Fireplace must be vented to the outside and must use one of the approved coaxial rigid ducting systems. You may also use an approved power vent. **Do Not Use any silicone sealants at pipe joints. Stove gasket cements may be used at pipe joints but is not required.**

The DXV35DT4 Fireplaces requires coaxial rigid- 4" diameter exhaust & 6-5/8" diameter air inlet and approved vent caps. All UL Listed Coaxial Rigid 4"X6-5/8" Vent pipe components and vent caps are approved for use. Do not mix components of different brands or series. Always use the same brand and series components throughout the entire vent system.

All warranties will be voided and serious fire, health or other safety hazards may result from any of the following actions: Installation by unauthorized personnel; installation of any damaged component; unauthorized modification of vent system; installation of any components not approved by Mendota; failure to meet all clearance requirements; failure to properly twist-lock and positively seal all components. Consult local building codes before beginning the installation.

WARNING: Always maintain required clearances (air spaces) to combustibles to prevent a fire hazard. Do not fill air spaces with insulation. Check installation instructions for minimum clearance requirements between the outer walls of the vent pipe and nearby combustible surfaces. Be sure to check the vent termination clearance requirements from decks, windows, soffit, gas regulators, air supply inlets, and public walkways, as specified in these installation instructions and local building codes.

SAFETY PRECAUTIONS FOR THE INSTALLER: 1) Wear gloves and safety glasses for protection; 2) Exercise extreme caution when using ladders or on rooftops; and 3) be aware of electrical wiring locations in walls and ceilings.

This gas appliance and vent system must be vented directly to the outside of the building, and never attached to a chimney serving another solid fuel or gas burning appliance. Each direct vent gas appliance must have its own separate vent system. Common vent systems are prohibited.

To assure proper venting performance of this high-performance Mendota Direct Vent Fireplace, it is critical that all brands of vent pipe sections are sealed tightly and leak-proof. This means that all pipe sections must be carefully rotated into the fully "twist-locked" position.

We strongly recommend that fixed length pipe sections be used in place of telescoping sections whenever possible.

3.2.3.1 COMPONENT "TWIST-LOCK" CONNECTION PROCEDURE

DuraVent and American Metals pipe and fittings are designed with special twist-lock connections. Twist-lock procedure is as follows: four (4) indentations, located on the female ends of pipes and fittings are designed to slide straight in to the male ends of the adjacent pipes and fittings, by orienting the four pipe indentations so that they match and slide into the four entry slots on the male ends.

Push the pipe sections completely together then twist-lock one section clockwise, approximately ¼ turn until the two sections are fully locked. The female locking lugs will not be visible from the outside on the black pipe or fittings. They may be located by examining inside of the female ends.

3.2.3.2 Wall Heat Shield for Horizontal Vent Caps

Always use heat shield (#AA-11-00458) when the exterior wall covering is made of vinyl, wood or other combustible materials. Heat shield (#AA-11-00458) or an equivalent heat shield shall be installed. Heat shield (#AA-11-00458) is available for order directly from Mendota fireplaces.

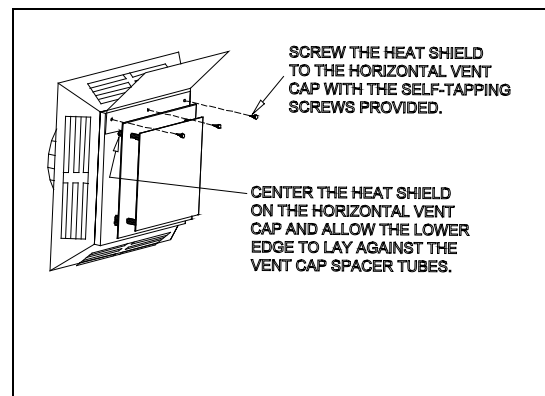
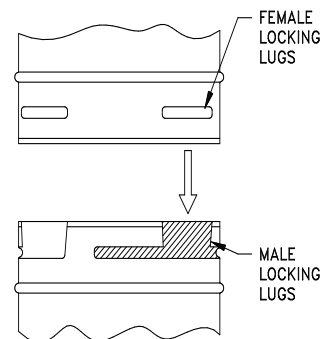

3.2.3.3 Flue Venting Components Identification Diagrams

Prior to installing at altitudes higher than 7500, please contact the Mendota technical service department for specific venting requirements and venting restrictions.

ITEM	DESCRIPTION
1	6" or 7" PIPE (DuraVent 6"/Amerivent 7"), 9", 12"
2	12" VENT STACK
3	24" VENT STACK
4	36" VENT STACK
5	48" VENT STACK
6	90° GALVANIZED ELBOW
6a	45° GALVANIZED ELBOW
7	ADJUSTABLE WALL THIMBLE
8	ATTIC INSULATION SHIELD 12"
9	ROOF FLASHING (0/12 TO 6/12)
10	ROOF FLASHING (7/12 TO 12/12)
11	STORM COLLAR
12	VERTICAL VENT CAP
13	SUPPORT BAND
14	HORIZONTAL VENT CAP
15	FIRE STOP SPACER

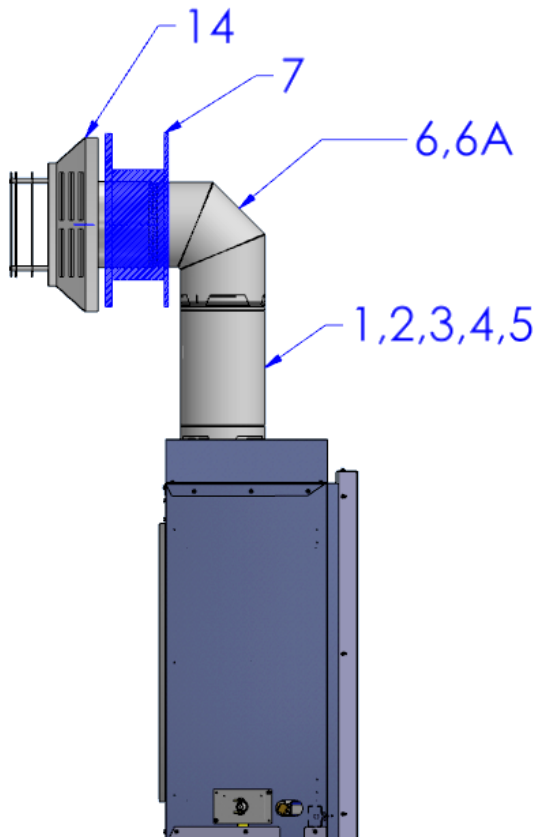
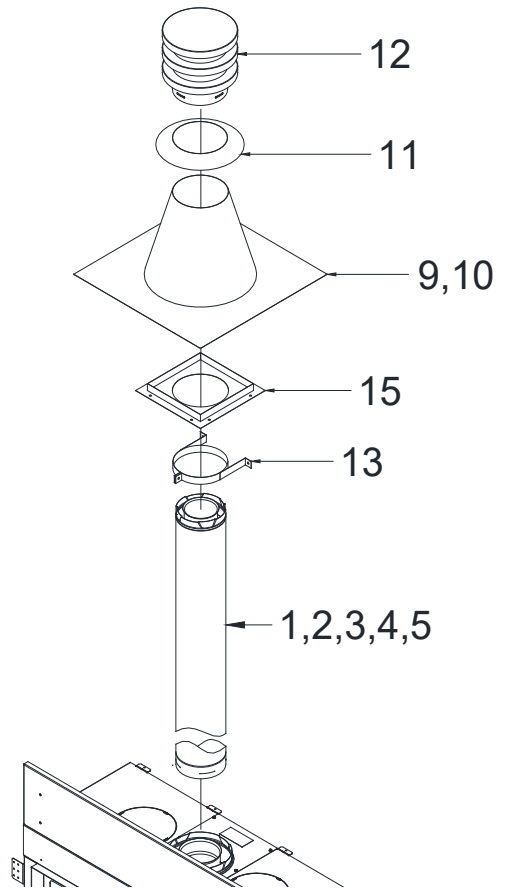

3.2.3.4 Approved Vent Systems

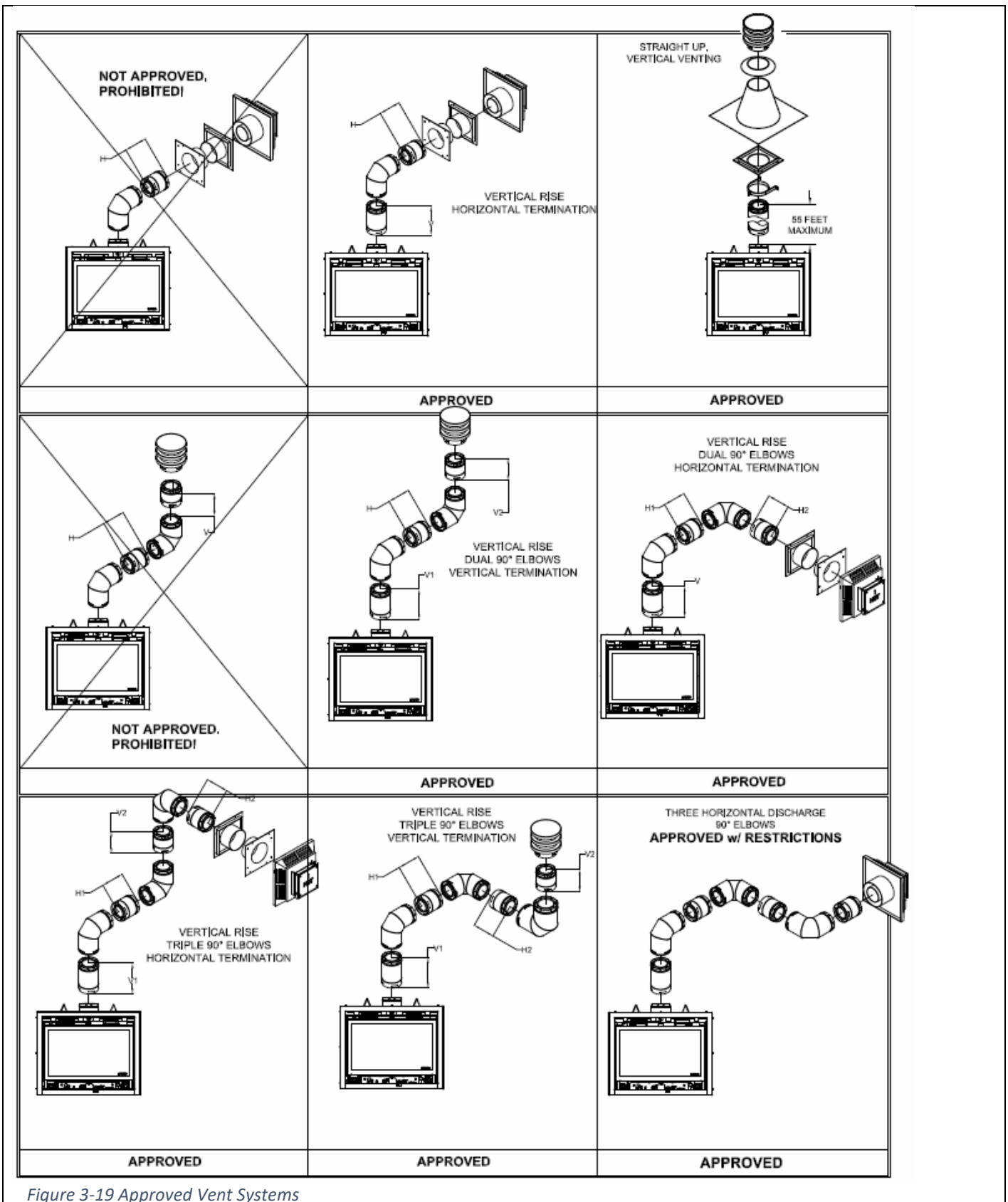
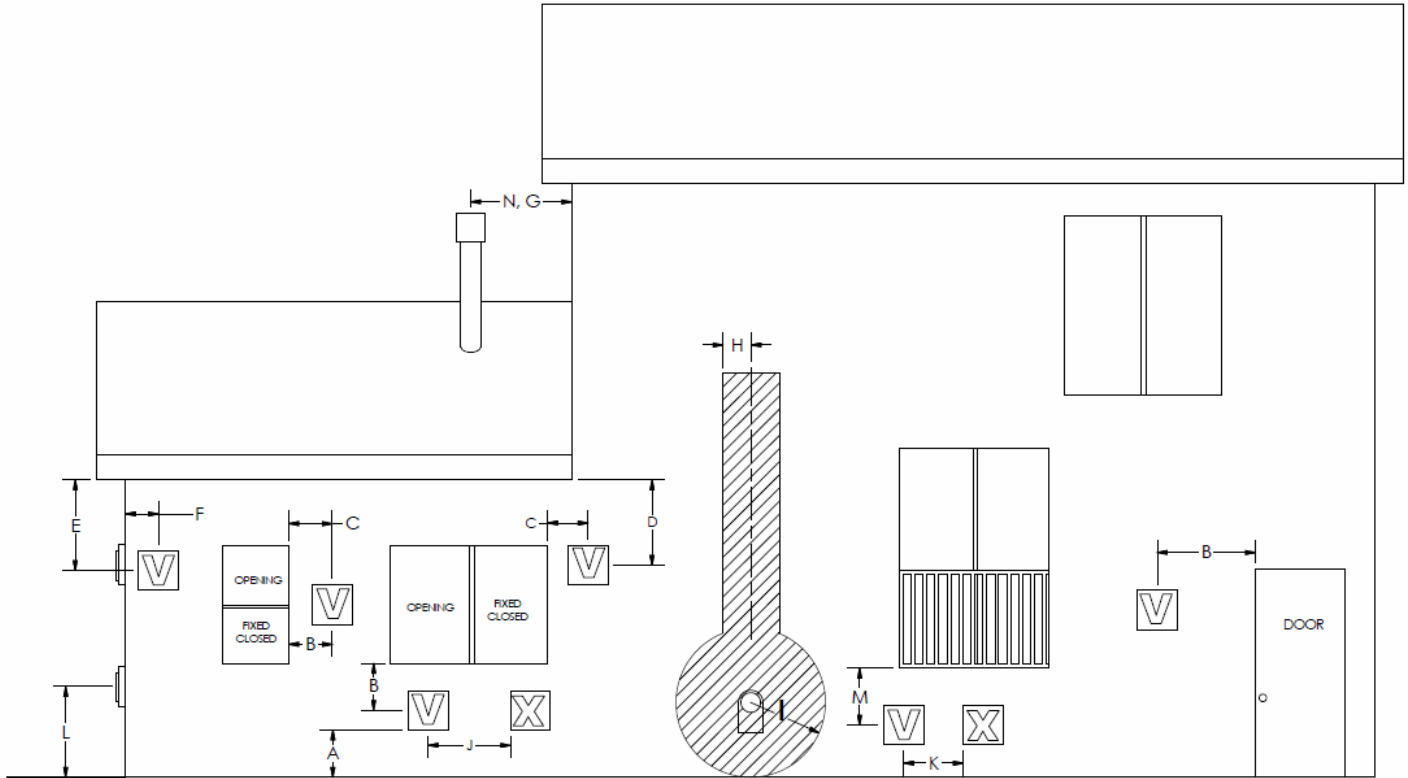

Figure 3-19 Approved Vent Systems

3.2.3.5 Exterior Vent Locations and Restrictions

Note: All measurements are to be taken from the center of the vent cap.



∇ - Vent Terminal		X - Air Supply Inlet		≡ - Area where terminal is not permitted	
A =	Clearance above grade, veranda, porch, deck, or balcony (*18 inches (45 cm) minimum)	H =		*Not to be installed above a meter/regulator assembly within 3 feet (90 cm) horizontally from the center-line of the regulator; within a height of 15 feet	
B =	Clearance to window or door that may be opened (*18 inches (45 cm) minimum.	I =		*Clearance to service regulator vent outlet *3 feet (92 cm) minimum.	
C =	*Clearance to permanently closed window (minimum 18 inches (45 cm) recommended to prevent condensation on window)	J =		*Clearance to non-mechanical air supply inlet to building or the combustion air inlet to any other appliance. 12 inches (30 cm) minimum.	
D =	*Vertical clearance to ventilated soffit located above the terminal from the center-line of the terminal 18" (45 cm) min. Minimum 24" (60 cm to Vinyl Soffit)	K =		*Clearance to a mechanical air supply inlet In USA, 3 feet minimum above, if within 10 feet horizontally. In Canada, 6 feet minimum	
E =	*Clearance to unventilated soffit 18" min (45 cm) min. Minimum 24" (60 cm to Vinyl Soffit)	L =		□ Clearance above paved side-walk or a paved driveway located on public property (*7 feet (2.1 m) minimum)	
F =	Clearance to outside corner - 12 inches (30 cm).	M =		Clearance under veranda, porch, deck, or balcony (*18 inches (45 cm) minimum □)	
G =	Clearance to inside corner - 12 inches (30 cm). Vinyl surfaces require 24" min (60 cm).	N =		Minimum 24" horizontal clearance to any surface, such as an exterior surface, for vertical terminations.	

3.2.3.6 Side by Side installation of two Vent Caps

When two or more vertical vent caps are located within proximity of one another, it is required that a galvanized steel 18-gauge or heavier barrier wall be installed between the two vent caps to eliminate recirculation of exhaust gases from one cap to another.

The galvanized steel barrier shall be 6" taller than the highest point of the vent caps and shall be 3" wider past the outer edges of the vent caps.

If two gravity direct vent system gas appliances are terminated next to each other, the minimum required distance between the vertical center line of the vent caps is 18" to prevent recirculation of exhaust from one vent cap outlet into the air intake of another vent cap.

If a wood burning flue opening is adjacent to a gravity direct vent system gas appliance vent cap and the distance between vertical center lines of the two terminations is less than 36", we recommend a metal divider plate be installed to prevent wood burning exhaust from entering the gas appliance air intake path. Alternatively, you may also vertically extend the wood burning flue liner up 24" higher than the top surface of the gas appliance vent cap.

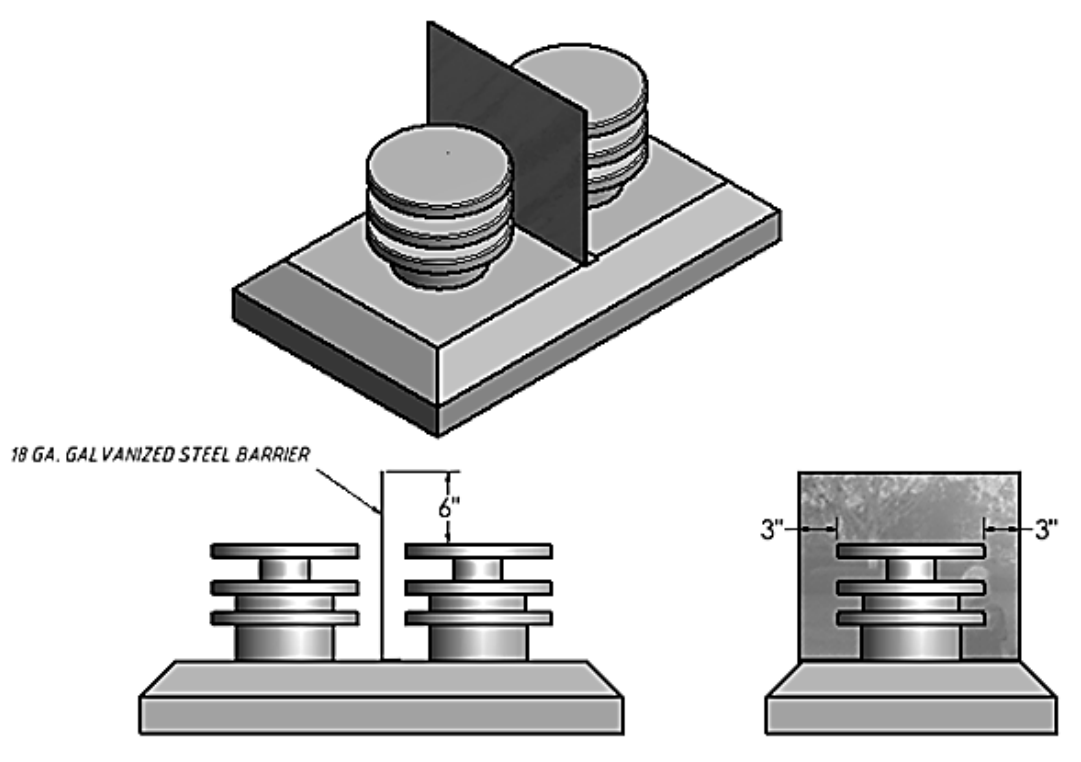

3.3 ELECTRICAL TECHNICAL REFERENCES

3.3.1 AC Power Requirements

WARNING: Label all wires prior to disconnection when servicing controls. Wiring errors can cause improper and dangerous operation. Verify proper operation after servicing.

For normal operation, this appliance requires 120 VAC, 2 Amp power or a 6V DC power source. The AC power supply to this Fireplace must be hot at all times and shall not have a switch installed in it.

This appliance is equipped with an electrical junction box on the left side. Backup DC power supply connector wire harness is supplied with this fireplace and shall be installed adjacent to this appliance. See [3.3.2 Backup DC Power Supply Information](#).

3.3.1.1 Planning for AC Power Connection

On the left-side of this appliance, you will find an electrical junction box with a strain relief clamp. To connect AC power to this Fireplace, follow these steps:

1. Remove the junction box cover plate (secured with two screws), route the 3wire end of an extension cord or house power wire cable through the strain relief in the cover plate.
2. Locate in the manual packet the plug shown in the photo. It is labeled TO HOUSE POWER.

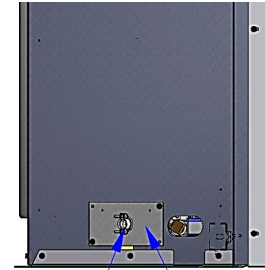

STRAIN RELIEF CLAMP AC JUNCTION BOX

Figure 3-20 Electrical Junction Box

3. Strip the ends of the house power wires and the three color coded wires within the junction box. Connect each color-coded wire to corresponding colored wires within the junction box. Use the supplied wire nuts to connect each wire pair ends.



Note: When connecting two braided wires using wire nuts, strip both braided wire ends at least $\frac{1}{2}$ " and twist the two bare ends together before using wire nuts. When connecting a braided wire to a solid copper wire, strip the solid copper wire end $\frac{1}{2}$ " and the braided wire end $\frac{3}{4}$ ". Twist the braided wire around the solid copper wire end before applying the wire nut.

4. Place connected wire ends within junction box then close and secure the junction box cover plate.
5. Plug the wire in to the back of the outlet box. The house power plugs into the plug that is towards the front of the fireplace. The plugs are designed so that they cannot be plugged into the wrong place.
6. Once the wire is plugged in, place the wire into the junction box and reinstall the cover plate.



3.3.1.2 AC Power Connection

STEP 1

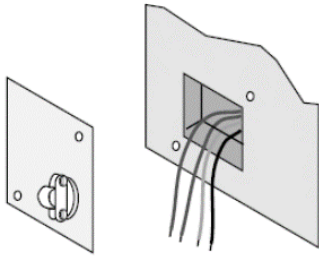

STEP 2

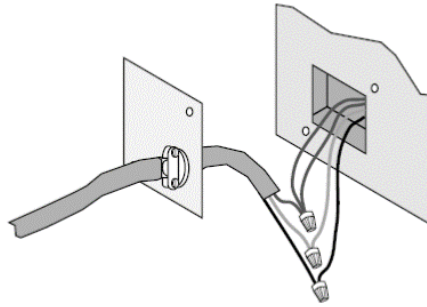

STEP 3

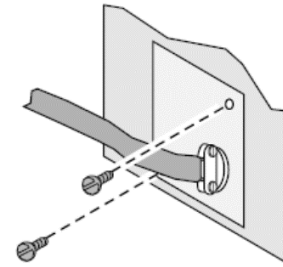

Figure 3-21 Wire Connections

3.3.2 Backup DC Power Supply Information

OPERATING DURING POWER OUTAGES

This electronic ignition system utilizes the supplied 110VAC power when it is available for all functions of this system. If the AC power is interrupted during a power outage, locate the backup battery holder on the far-right side of the courtesy panel behind the lower grill. Using $\frac{1}{4}$ " hex driver or a flat screw driver, remove two screws and remove the battery pack holder. Insert four fresh AA batteries in the battery pack and operate the appliance.

During the power outage, the appliance's burners will function. In addition, Flame Height adjustment and Secondary Burner ON/OFF functions will be available. The Fan and Accent Light, which are wholly dependent on 110VAC power, will not function.

This appliance is designed and tested to be operated during power outages.

You may operate this appliance indefinitely on battery power as long as you accept that high capacity DC 6-volt batteries will be required to sustain uninterrupted DC power to this appliance and that the blower function and accent light functions will not be available

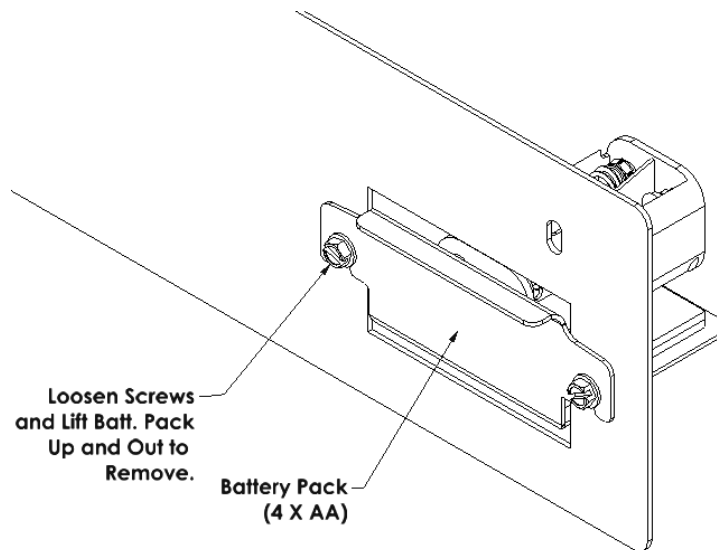
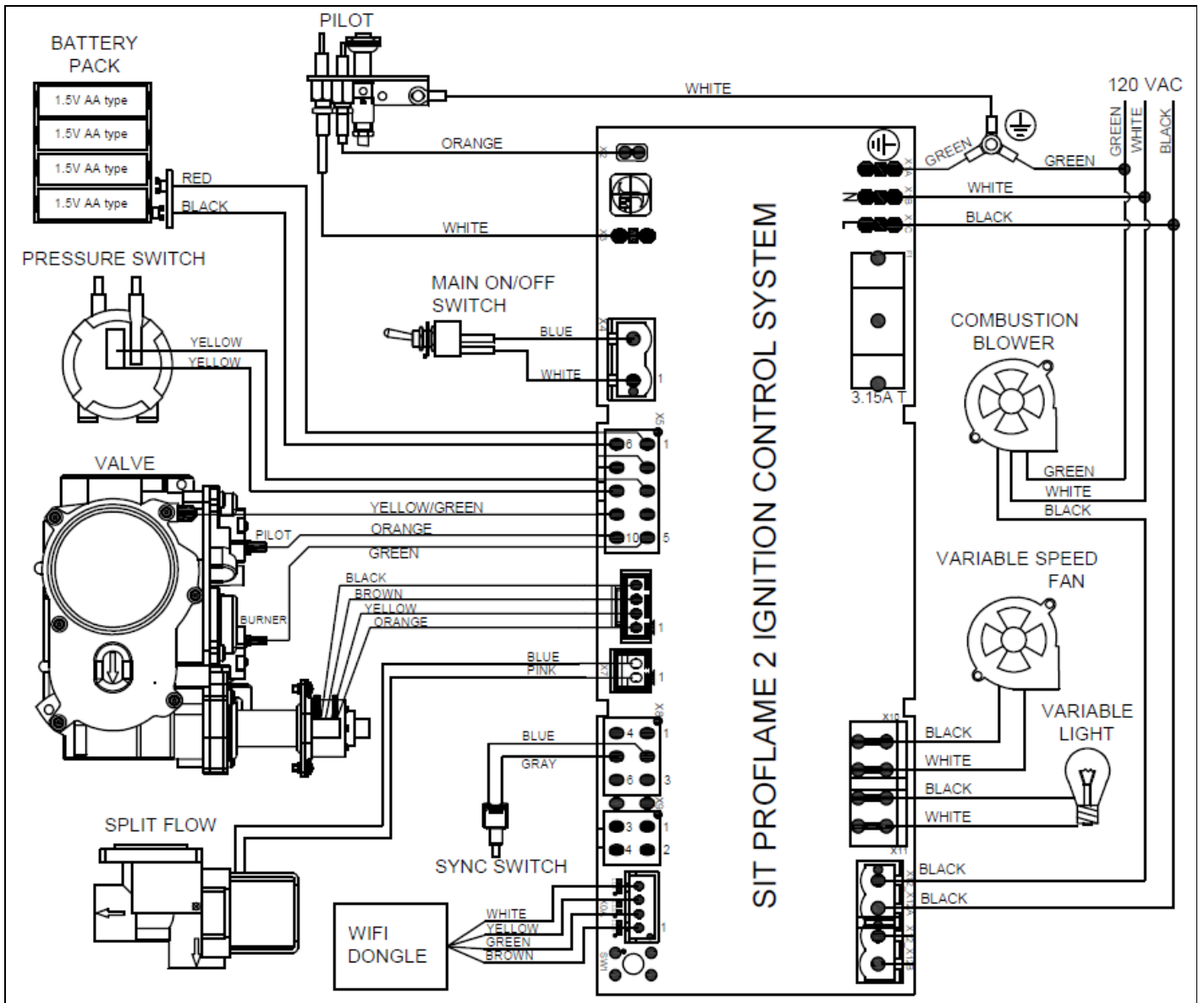

Figure 3-22 Backup Battery Pack

3.3.3 PF2 Ignition System Diagram



Note: Connect wires in junction box located on the right side of this appliance to house power using supplied wire nuts.

Note: On Décor models, the Split Flow circuit is not installed nor used.

Replacement wires must have the same type and size of insulation as the original.

This appliance must be electrically connected and grounded in accordance with local codes or, in the absence of local codes, with the current NFPA 70- National Electric Code or CSA C22.1- Canadian Electrical Code.

Label all wires prior to disconnection when servicing control. Wiring Errors can cause improper and dangerous operation. Verify proper operation after servicing.

3.4 PLUMBING TECHNICAL REFERENCES

3.4.1 Gas Supply Requirements

NOTE: if Fireplace is to be operated with LP gas, see Chapter 4.4 [Natural Gas to LPG Conversion](#) in this manual before proceeding.

CORRECT GAS PRESSURE AND PROPER GAS SUPPLY LINE SIZING IS IMPERATIVE TO THE SUCCESSFUL PERFORMANCE OF YOUR MENDOTA GAS FIREPLACE. BE SURE THE GAS SUPPLIER OR PLUMBER CAREFULLY CHECKS FOR CORRECT GAS PRESSURE AND GAS LINE SIZING WHEN INSTALLING THE FIREPLACE.

IT IS CRITICAL TO CAREFULLY CHECK FOR GAS LEAKS WHEN HOOKING UP THE FIREPLACE. CHECK WITH SOAP AND WATER SOLUTION OR COMBUSTIBLE GAS SNIFFER.

BE SURE TO INSTALL CSST FLEX GAS LINE WITH BRASS-TO-BRASS FITTINGS TO PREVENT GAS LEAKS AT CONNECTIONS.

GAS SUPPLY PIPING MUST INCLUDE A DRIP LEG TO ELIMINATE THE POSSIBILITY OF CONTAMINANTS ENTERING THE GAS TRAIN. ADHERE STRICTLY TO LOCAL AND NATIONAL CODES.

3.4.2 Gas Supply Line Sizing

This Mendota Gas Fireplace comes equipped with a 1/2" N.P.T. Female inlet. Gas supply piping must enter the Fireplace cabinet on the left side.

Use the table, below, to determine the proper gas line diameter that must be installed to run from the supply regulator to the inlet end of the main gas valve. Refer to the following table for proper gas pipe diameters.

PIPE LENGTH [FEET]	SCHEDULE 40 PIPE INSIDE DIA.		TUBING, TYPE L OUTSIDE DIAMETER	
	NAT.	L.P.	NAT.	L.P.
0-10	1/2" [1.3 cm]	3/8" [1.0 cm]	1/2" [1.3 cm]	3/8" [1.0 cm]
10-40	1/2" [1.3 cm]	1/2" [1.3 cm]	5/8" [1.6 cm]	1/2" [1.3 cm]
40-100	1/2" [1.3 cm]	1/2" [1.3 cm]	3/4" [2.0 cm]	1/2" [1.3 cm]
100-150	3/4" [2.0 cm]	1/2" [1.3 cm]	7/8" [2.3 cm]	5/8" [1.6 cm]
150-200	3/4" [2.0 cm]	1/2" [1.3 cm]	7/8" [2.3 cm]	3/4" [2.0 cm]

NOTE: Some areas allow copper tubing or galvanized pipe - check with local approval agencies and codes *NEVER* use plastic pipe.

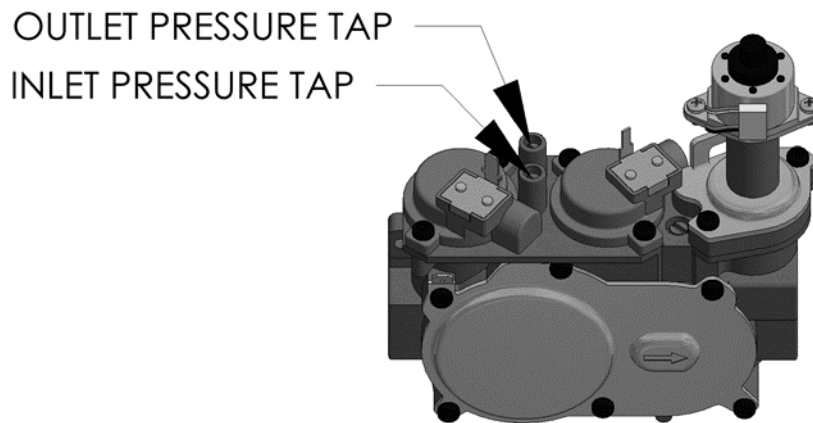

Figure 3-23 Gas Pressure Test Ports

3.4.3 Gas Pressure Requirements and Checking

Two pressure taps for checking input and output gas pressures are located on the main gas valve. A qualified installer should use this fitting for setting the correct gas pressure during initial installation.

The appliance and its appliance main gas valve must be disconnected from the gas supply piping system during any pressure testing of that system at test pressures in excess of 1/2 psi (3.5 kPa).

The appliance must be isolated from the gas supply piping system by closing its equipment shut-off valve during any pressure testing of the gas supply piping system at test pressures equal to or less than 1/2 psi (3.5 kPa).

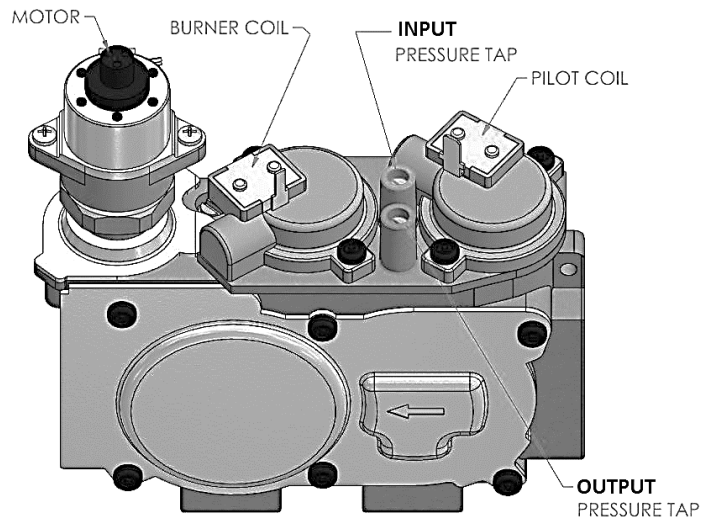

Figure 3-24 Main Gas Valve

3.4.4 Drip Leg Recommended

It is recommended that a drip leg/sediment trap is installed within the main gas supply line serving this appliance.

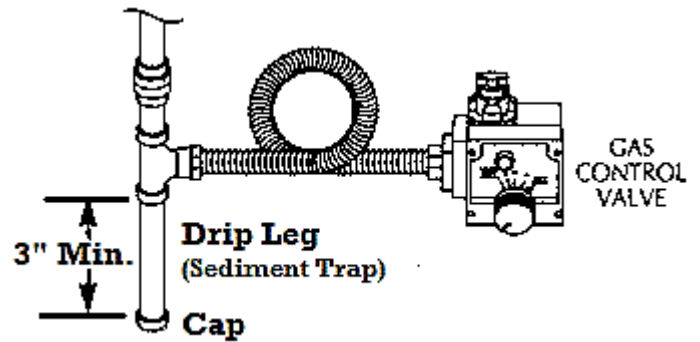

Figure 3-25 Drip Leg/ Sediment Trap

3.4.5 Manual Gas Shutoff Valve Requirement

If local building codes require one, obtain an external keyed wall-mounted or floor-mounted manual gas shutoff valve approved per local gas plumbing codes and install per local gas plumbing codes in the specified location. Local requirements supersede all other codes.



Figure 3-26 Keyed Manual Gas Shutoff Valve

3.4.6 Factory Installed Manual Gas Shutoff Valve

A manual gas shutoff valve is factory installed and located in the lower convection chamber. To operate the manual gas shutoff valve, rotate the red shutoff handle clockwise to open and counterclockwise to close.

3.4.7 Gas Inlet Fittings Information

Caution: Before you run the gas line, read, understand and properly calculate the required gas line size. Improper (too small) gas line size application can lead to improper burner ignition and can cause property damage and/or injury. If you are not qualified or certified to run a gas line, do not proceed. Contact a qualified Gas Plumber.

The gas inlet fitting supplied with this Fireplace provides a 1/2" female NPT fitting. This requires you to supply a 1/2" NPT male fitting for connection to this appliance.

Based on the gas line size you have selected use an appropriate NPT fitting to adapt and connect to the 1/2" male NPT end adapter.

3.4.8 Gas Input Rate Verification

3.4.8.1 Natural Gas Input Rate Verification

1. Verify main orifice size. The main orifice body has the orifice hole size stamped on it. NG orifice size shall be #44 (rear burner) and 3/64" (front burner) for all elevations.
2. Verify that the Manifold Gas Pressure is within 3.5" WC +/- 1/8". Once setup, read the main home gas supply meter reading.
3. Write the initial reading here >> initial gas meter reading _____
Turn off all other appliances and their pilot flame in the home.
4. Run this appliance for a period of 30 minutes on maximum flame size. Turn off main burner and pilot flame. Read the main home gas supply meter reading after the 30 minutes of burn time.
5. Write the reading here >> final gas meter reading _____
Calculate the following:
6. FINAL GAS METER READING - INITIAL GAS METER READING...Subtract initial gas meter from final gas meter reading. This will yield the number of Therms used during the 30-minute burn time.
7. Multiply the result in Item #6 by 100,000.
8. Multiply the result in Item #7 by 2. Write down the result here >> _____
9. The result in item #8 shall be at least the maximum input rate (33,000 Btu/hr) for all altitudes.

3.4.8.2 LPG Input Rate Verification

Verify main orifice size. The main orifice body has the orifice hole size stamped on it. LPG orifice size shall be #49 (rear burner) and 3/64" (front burner) for all elevations.
Verify that the manifold gas pressure is within 10.0" WC +/- 1/8".

3.4.9 High Altitude De-Rating

If you are de-rating this appliance at a high altitude, attach the High Altitude De-Rating Label, supplied in the Owner's Manual Packet, to the back surface of the listing label plate located in the air gap on the side of the Fireplace. If you are also converting the Fireplace for LP Gas attach the labels included with the conversion kit to the same surface. Prior to attaching the label, fill in all the information that is requested on the label.

For installations from 610-1370 meters (2000-4500 ft.) the orifice sizes (DMS) for Natural Gas are #44(Rear) and 3/64"(Front) and Propane Gas are #49(Rear) and 3/64"(Front), respectively. See data plate for additional information. For high altitude installations consult the local gas distributor or the authority having jurisdiction for proper rating methods. If the installer must convert the unit to adjust for varying altitudes, the information sticker must be filled out by the installer and adhered to the appliance at the time of conversion."

This appliance has been converted for use at an altitude of:	
Orifice size:	Manifold Pressure:
Input (Btu/h):	Fuel Type:
Date of conversion:	Converted by:

Cet appareil a été converti au ____ Injecteur _____ Pression à la tubulure d'alimentation _____ Débit calorifique _____
--

4 INSTALLATION INSTRUCTIONS

4.1 INSTALLATION CHECKLIST

The instructions provided in this chapter are arranged in the sequence of occurrences.

This installation checklist is supplied as a guide for installers to follow step by step. As you complete each step of the installation work, check mark the completed work item in the list, below. All items in this installation checklist must be completed. When all work is complete, fill in your name and the date this installation was completed.

- Unpack the Fireplace body.
- Open and inspect the Manual Packet.
- Unbolt the Fireplace body from the wooden pallet.
- Bend up the shipping clips.
- Place Fireplace body inside Framed Chase, level and plumb fireplace body and secure to framing studs.
- Open the Fireplace Glass Door.
- Install the Accent Light bulb and Light Lens.
- If planning to burn LPG, perform the NG to LPG conversion work.
- Measure chimney Length required.
- Install Vent System.
 - Sealant is not required at vent joints. **Do not use silicone sealants in vent connection joints anywhere.**
 - Adjust vent damper to match vertical chimney length. See [4.5.13 Vent Damper Adjustments](#).
 - Co-axial vent rigid pipe, wall vent cap or roof vent cap is installed by a Mendota approved serviceperson in accordance with instructions.
 - All joints are secured, "twist-locked" and leak-proof.
 - Horizontal or vertical vent cap is installed "right-side-up" and tightly sealed to structure per instructions. Vent Caps are Mendota approved.
 - Proper exterior and interior clearances for vent systems and locations for wall vent cap/roof vent cap are maintained.
 - Correct gas pressure, proper size gas lines and gas leaks are checked.
 - 120 V electrical service and gas supply is installed in accordance with instructions and local and national codes.
 - Telescoping sections are not separated. They were used as complete assemblies.
- Connect Gas Supply to the Fireplace. Verify that gas pressures are proper and perform a complete leak test of all field installed gas joints and factory installed gas train joints using a gas sniffer.
 - Verify orifice sizes.
 - Verify gas input rates.
- Connect Electrical Supply to the Fireplace. See [3.3.1.2 AC Power Connection](#) .
- Install firebox inner liner kit. Follow instruction supplied with the Liner Kit.
- Install log set, coals and inswool media.
- Install Glass door and assure that it is in proper closed position and centered in firebox opening.
- Test fire Fireplace.
- Teach consumer how to use remote control and all functions of this Fireplace
- Complete warranty registration at <http://mendotahearth.com/gas-fireplace-and-stove-registration.php>

This installation was performed and completed by:

Date:

4.2 PREPARING FOR INSTALLATION

4.2.1 Unpacking the Fireplace

The Fireplace arrives from the factory on a wooden pallet with a cardboard box encasing the pallet and Fireplace. To remove the outer box, identify and remove four Philips head drywall screws that secure a cardboard L pincher at the bottom of each corner of the box.

Lift the outer box vertically straight upward until lower edge of the box clears the top of the unit body. Set the box aside. Mendota recommends recycling the outer box.

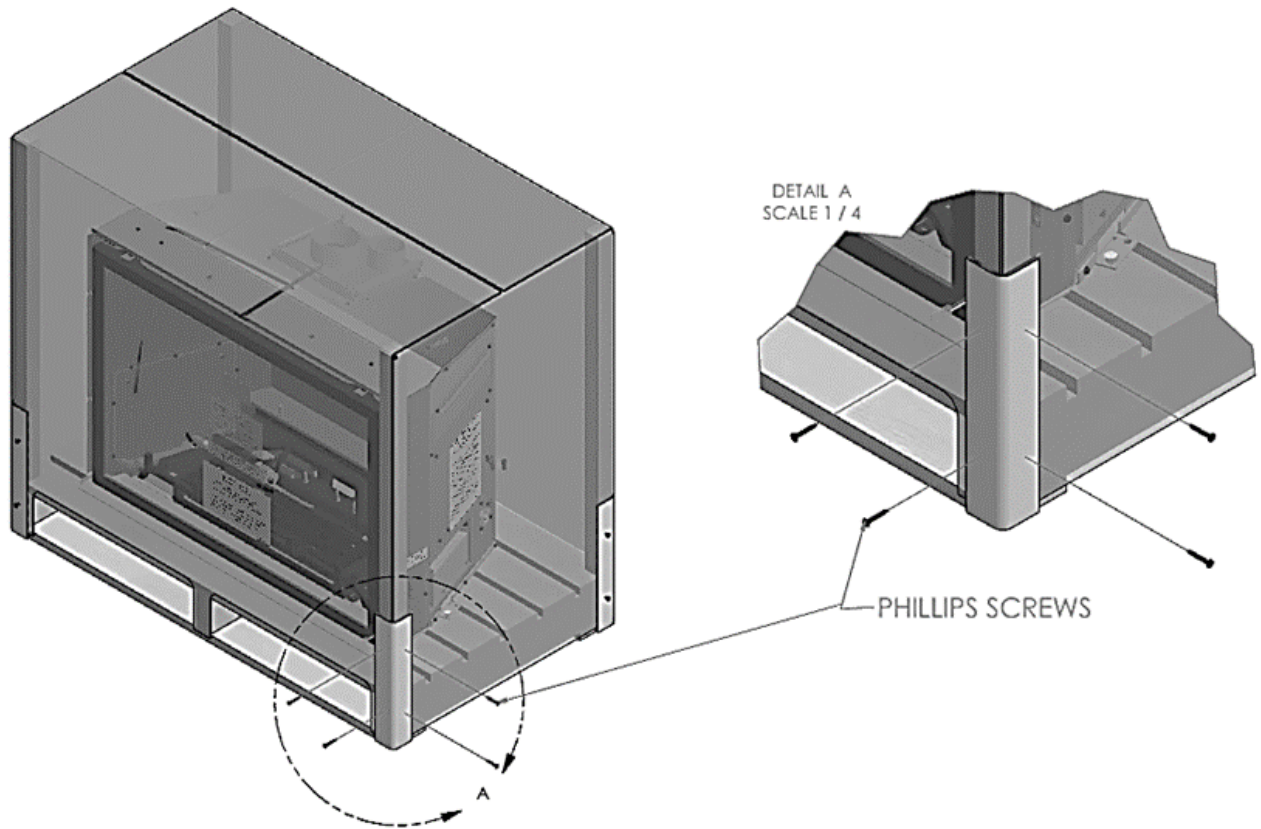

Figure 4-1 Outer Box Removal

4.2.2 Contents of the Manual Packet

Once the outer box is removed, you will find the Fireplace body and a manual packet white box. This manual packet white box includes the items shown in the table, below. Contact Mendota Technical Service if any parts are missing.

<p>Glass Latch Tool #HA-77-00256 Must Leave with Homeowner.</p>	
<p>Remote Control Transmitter # HA-110-00105. 3-AAA Batteries # 65-06-01270. Must Leave with Homeowner.</p>	
<p>Backup Battery Holder #05-02-00345 & QTY 4- AA Batteries #65-06-01147. Must Leave with Homeowner.</p>	
<p>Backup Power Harness #10-03-00128 Must Leave with Homeowner.</p>	
<p>Owner's Manual. Must Leave with Homeowner.</p>	<p>This Manual</p>

Figure 4-2 Manual Packet Contents

4.2.3 What is not included with this Appliance?

Log set, LP Conversion Kit or decorative front are not included with this base Fireplace product. One of many log set options, firebox inner liner options and decorative fronts options must be selected and purchased separately. Also order an LP Conversion Kit is required.

4.2.4 Unbolting Fireplace from Pallet

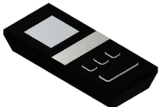
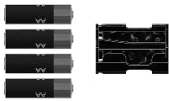
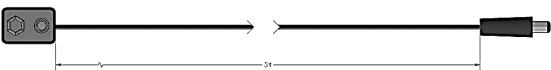
The Fireplace body is bolted to the pallet top surface using 5/16" X 1" Lag Screws in three points. One on each side and one or more at the rear. Use a 1/2" socket and wrench to remove the lag screws and detach fireplace from the pallet top.

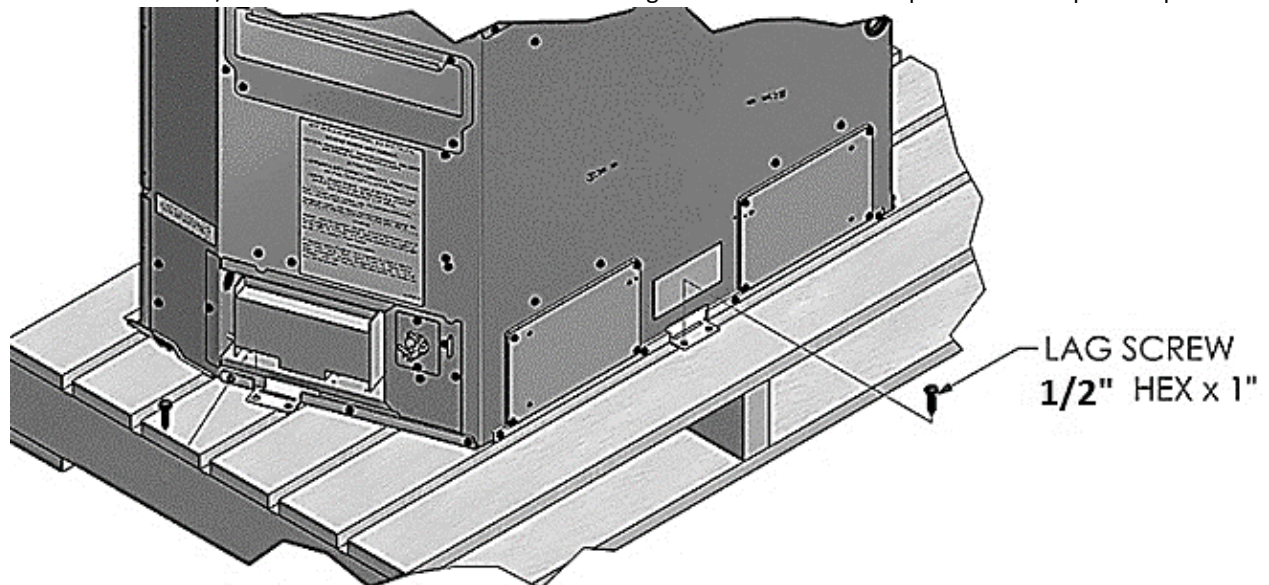

Figure 4-3 Unbolting Unit from Pallet

4.2.5 Bending up the shipping clips

Once the unit is detached from the pallet by removing the securing lag screws that hold these shipping clips to the pallet, either bend these clips up 90-degrees or break them off using a screw driver and back and forth cold working motion (see below). A bending relief is provided within the clip to ease bending or breaking. Bending the shipping clips up or removing them will be necessary for Fireplace units which are to be installed in narrow width or shallow depth openings.

To bend the clips up or to break them off, follow these procedures:

1. Fireplace the tip of a flat screw driver (longer screw driver is better) under the clip.
2. Lift screw driver handle upwards and bend the clip up about 45-degrees.
3. Remove screw driver. Insert screw driver tip into one hole in clip. Lift screw driver up. To break clip off, repeat up down motion of screw driver seven to eight times.

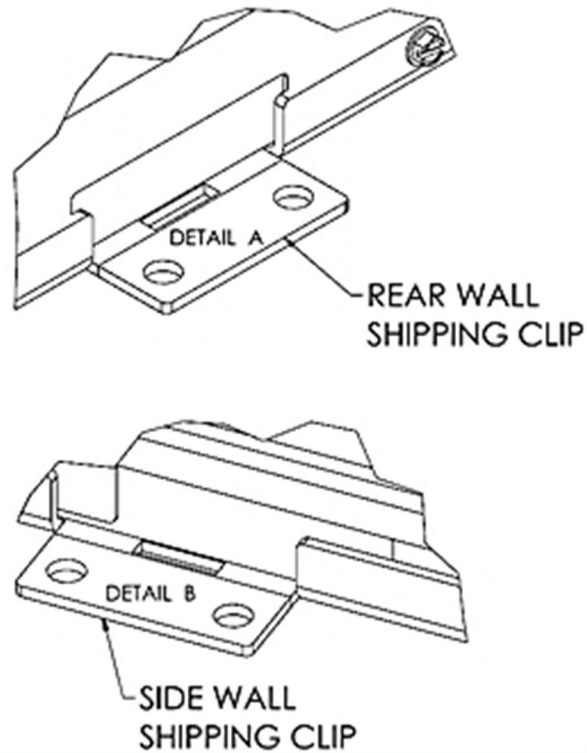

Figure 4-4 Shipping Clip

STEP 1 & STEP 2

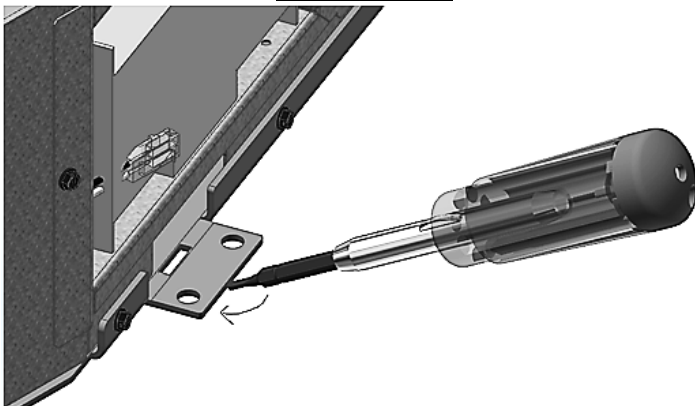

Figure 4-5 Bend Up Clip 1

STEP 3



Figure 4-6 Bend Up Clip 2

4.2.6 How to Remove Door

Use the glass latch tool to disconnect the spring latches from the glass frame. Insert tool into hole in latch, pull towards you and rotate 90-degrees to disengage top latches. Remove tool. There are two spring latches on top of this gas fireplace. Always make certain the hook glass latches are in the upside-down position after removing the glass frame. This upside-down latch position will make it easier to reinstall the glass frame later.

With both hands, rotate top edge of glass frame away from unit, approximately 8".

Lift glass frame up 1", at an angle, and move away from unit.

Door is now free from unit.

NOTE: Always check glass gasket condition and gasket seal any time the glass door is removed and when reinstalling glass door.

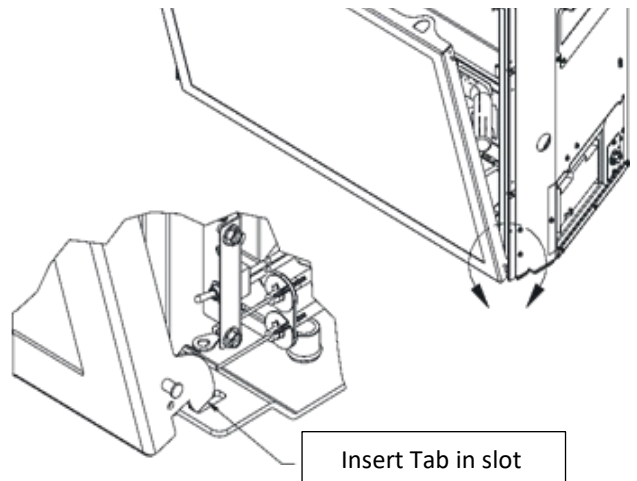

4.2.7 How To Replace Door

1. Line up the two bottom tabs in glass frame bottom (left and right sides) with slots on the sides of the firebox bottom. Insert tabs into slots and center tabs in slots, left to right.
2. Center glass frame over firebox; left to right.
3. After door has been placed into slots, rotate door towards firebox until gasket seal is touching the firebox frame.
4. Use the tool provided to connect the spring latches to the glass frame. Insert tool into hole in spring latch, pull latch towards you, rotate latch so the hook is facing downward then release latch to hook to door frame.

Door is now connected and sealed to unit.

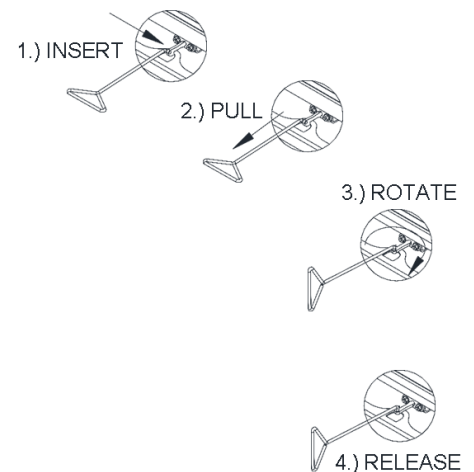
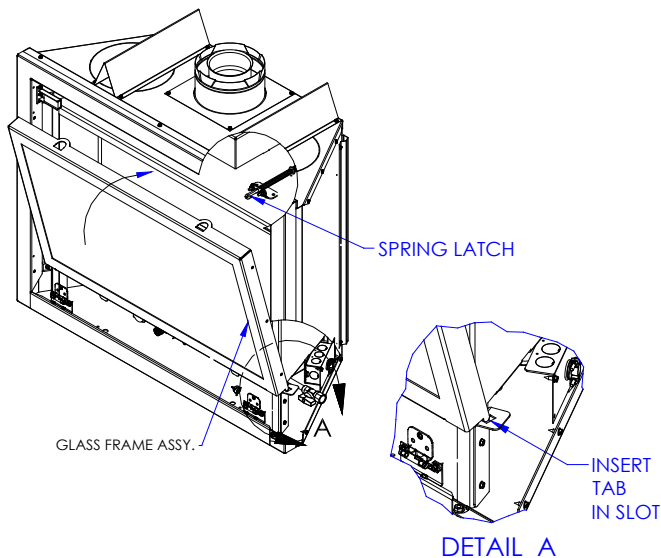

4.3 LIGHT BULB AND LIGHT LENS INSTALLATION

WARNING: Failure to position the parts in accordance with these diagrams or failure to use only parts specifically approved with this appliance may result in property damage or personal injury.

Before you install a firebox inner liner kit or a log set, install the accent light bulb and the accent light lens kit. To install the light bulb and light lens kit, follow these instructions:

1. Identify the light bulb socket. It is located within the top metal baffle, inside a hole in the metal baffle.

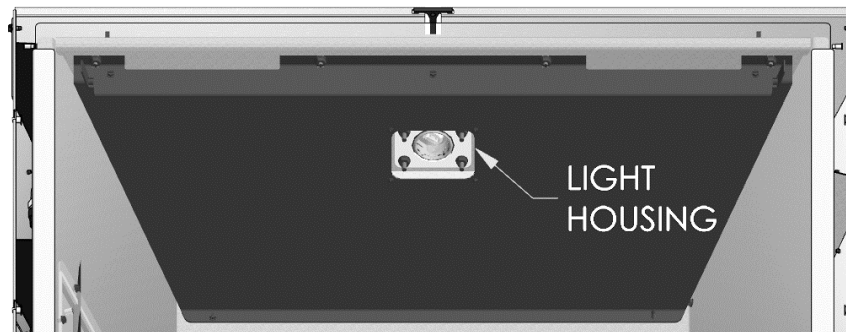

Figure 4-7 Light Housing

Caution: Do not touch the light lens with bare hands. Always use the protective foam wrap supplied with the light bulb or a pair of clean cloth or neoprene gloves to handle the light bulb. Touching the light bulb will leave oils and dirt on the lens and will cause premature failure of the light bulb.

2. Slide base of light bulb inside light bulb holder base after aligning the bulb base shape with the recessed shape in the bulb holder. Push up all the way.
3. Next, see diagrams, below. Install the light lens base gasket, light lens, light lens retainer bracket and the four retaining 10-24 nuts.

Warning: Use a 3/8" hex hand driver to tighten nuts. DO NOT over tighten the nuts. Doing so can crack the light lens.

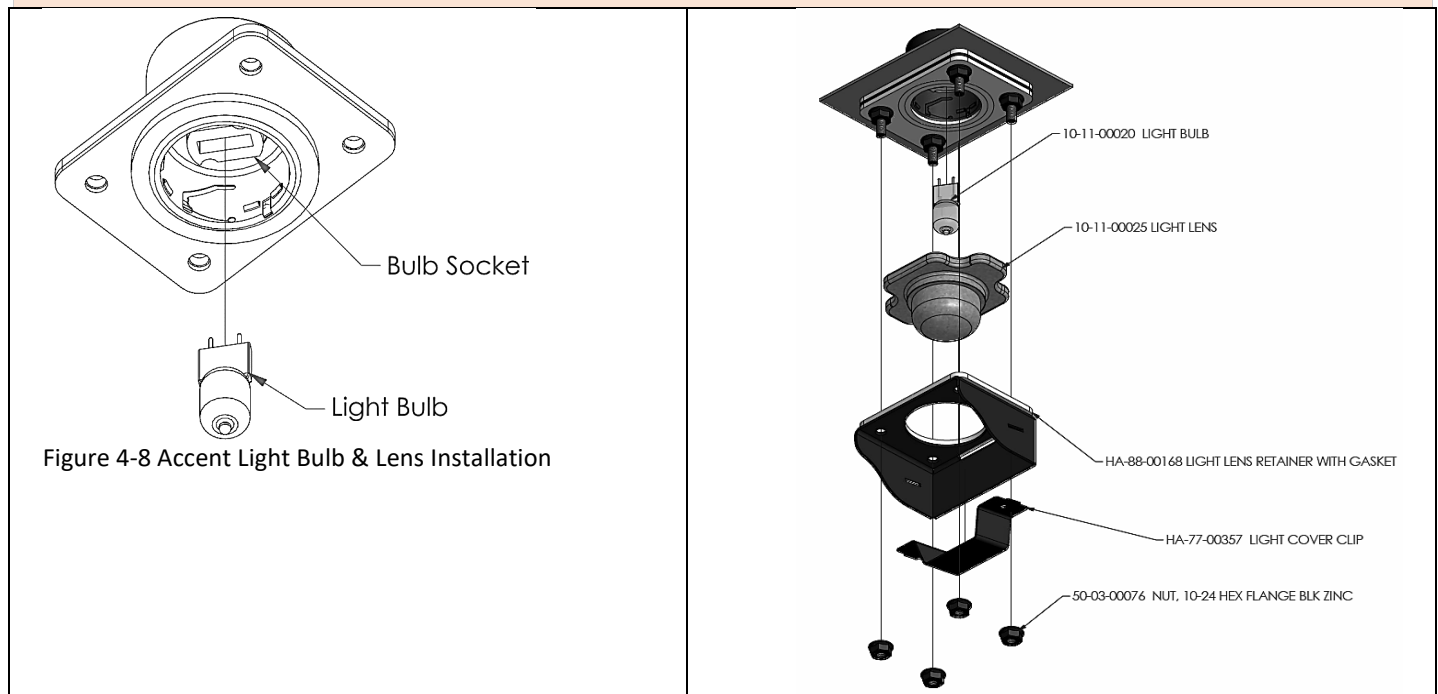

Figure 4-8 Accent Light Bulb & Lens Installation

4.4 NATURAL GAS TO LPG CONVERSION

WARNING

This conversion kit shall be installed by a qualified service agency in accordance with the manufacturer's instructions and all applicable codes and requirements of the authority having jurisdiction. If the information in these instructions is not followed exactly, a fire, explosion or production of carbon monoxide may result causing property damage, personal injury or loss of life. The qualified service agency is responsible for the proper installation of this kit. The installation is not proper and complete until the operation of the converted appliance is checked as specified in the owner instructions supplied with the kit.

WARNING: Failure to position the parts in accordance with these diagrams or failure to use only parts specifically approved with this appliance may result in property damage or personal injury.

A natural gas to LP gas conversion kit #HA-30-00507 must be ordered and installed in this fireplace to burn LP gas.

LP conversion kit #HA-30-00507 contains the following parts: one motorized LP pressure regulator #907.012, two cap orifices #65-14-00364 (drill $3/64$ "), an L-shaped Torx wrench and an LP conversion label.

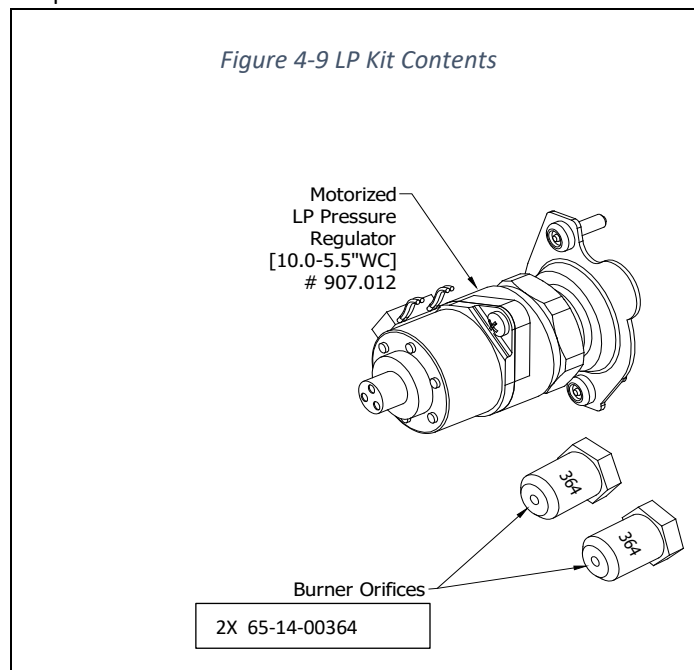

4.4.1 Procedure to Convert Fireplace for LP Gas

This fireplace arrives from the factory ready to burn natural gas. If you intend to burn LP gas, it is highly recommended that you convert this fireplace and its pressure regulator, pilot natural gas/LP clip position and burner orifices prior to placing this fireplace in its fireplace cavity.

Follow the step below to prepare this fireplace for conversion to LP gas:

1. Shut off the gas supply to the valve and shut down the electric supply.
Note: Be careful when removing or tightening the screw on the pressure regulator. Care must be taken to ensure a proper seal when tightened. Using a $1/4$ " Hex Driver, remove 2 screws that secure the Rear and Front burners to the Burner Airbox.
2. Lift Up and remove Front Burner.
3. Loosen Front Burner Air Shutter Screw and rotate air shutter open $1/4$ " minimum. Set burner aside.
4. Slide Rear Burner to the right about 2" and lift up and remove from Firebox.
5. You will now be able to access the burner orifices, which are located inside the air shutter boxes.
6. Using a $1/2$ " deep well socket wrench, remove front and rear orifices. When removing and installing the orifices be sure to use a wrench to keep the fitting the orifice screws onto from rotating.
7. Thread a new $3/64$ " orifice on both the front and rear orifice mounting brass fittings. Tighten down the orifices.

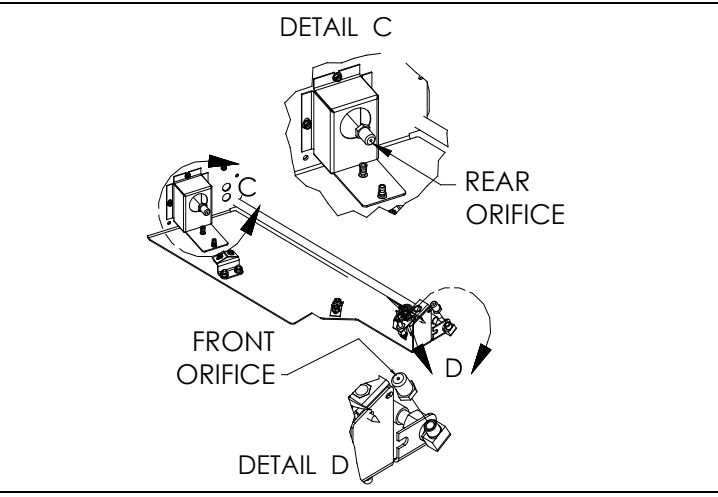
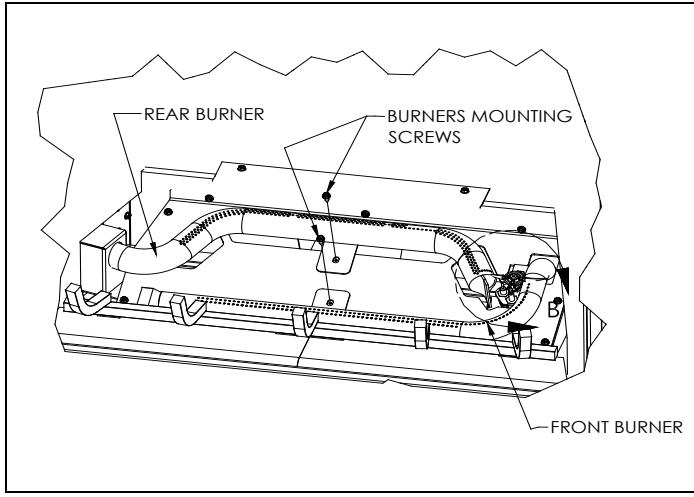

CAUTION: Always use one 7/16" open end wrench and one large pliers or vice grips tool to hold, loosen and tighten pilot hood base to prevent damage to pilot mount bracket.

7. While holding the pilot base body with large vice grips tightly, loosen the pilot's hex-shaped base using a 7/16" open end wrench. Rotate counter clock-wise ¼ turn to loosen.
8. Pilot arrives from the factory set for natural gas. Push natural gas/LP adjustment clip inward all the way to set it for LP. See detail view, below. If you see "NAT" printing on the adjustment clip, this indicates that the pilot is set to burn natural gas. Push the clip in so that "NAT" is not visible.
9. Tighten down hex-shaped base of pilot using a 7/16" open end wrench.
10. Install the airbox and both rear and front burners in their original locations and positions and secure down using screws you removed earlier.
11. Make certain front burner is running parallel to front face of unit positioned properly so that the pilot hood pointing to the left is pointed properly toward the burner's flame propagation ports.
12. Make certain rear burner is positioned properly so that the pilot hood pointing to the back is pointed properly toward the burner's flame propagation holes.

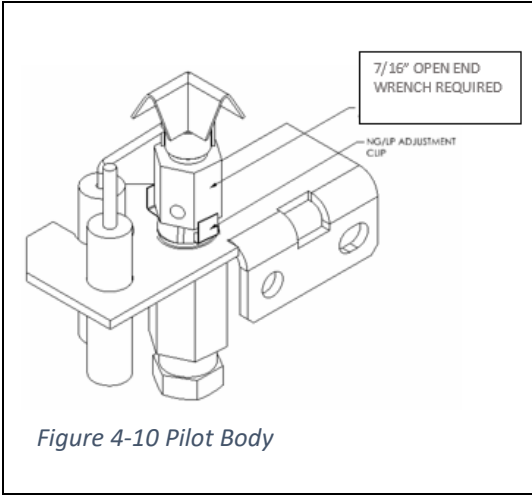

Figure 4-10 Pilot Body

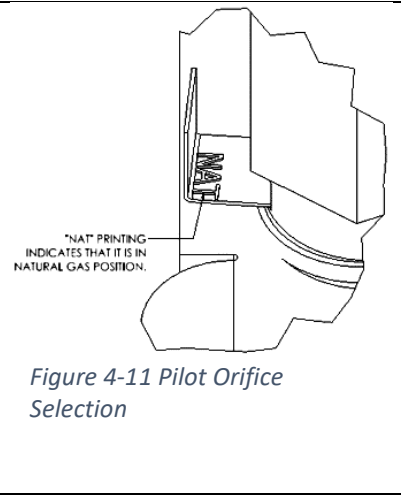

Figure 4-11 Pilot Orifice Selection

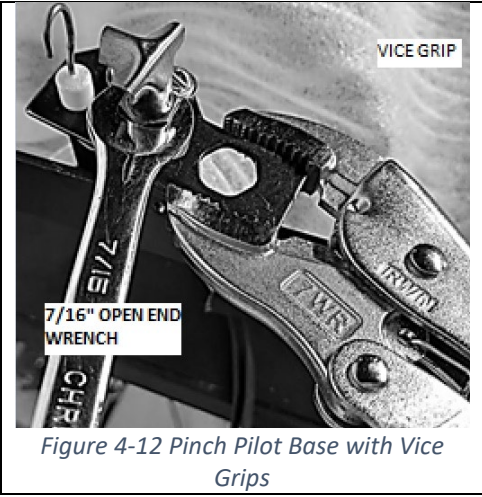

Figure 4-12 Pinch Pilot Base with Vice Grips

13. Next, the pressure regulator will be changed. To do this, first remove the courtesy panel that covers the gas valve and lay down gently without disconnecting any wires of internal components. **Warning: Do not force. Excessive force may damage internal wiring components.**
14. See diagrams below and identify the pressure regulator on the valve body. Remove the left side controls access panel. Gas valve and the pressure regulator mounted on the gas valve are accessible through the opening on the left side.

4.4.2 Pressure Regulator Conversion

WARNING: Failure to position the parts in accordance with these diagrams or failure to use only parts specifically approved with this appliance may result in property damage or personal injury.

1. See Figure 3-12-1: Using a Torx T20 (supplied) or slotted screwdriver, remove and discard the two pressure-regulator mounting screws (A); pressure-regulator tower (B); and the spring and diaphragm assembly (C), if applicable.
2. See Figure 3-12-Figure 2: Ensure the rubber gasket (D) is properly positioned. The rubber gasket is pre-fitted as part of assembly (E).
3. See Figure 3-12-Figures 3 and Figure 3-12-4: Install the new stepper motor pressure regulator assemble. Use the provided screws (F), M4 x 0.7 threaded; length of thread $L = (16\text{mm} + 0 - 0.5\text{mm})$, steel material, resistance class 8.8 (Figure 3-12-5).
4. Manually thread the two-conversion kit mounting screws into the valve body. Use a standard screwdriver or T20 Torx bit and tighten to the screws with a fixing torque of 25lb-in, plus or minus 5.
5. Note: If the threads of the valve are stripped or damaged, replace the valve.
6. Install the enclosed identification label (G) to the valve body where it can be easily seen.

Warning: Installation should be carried out in a clean environment.

Warning: This modulating conversion kit must only be applied as part of a conversion kit supplied by the fireplace manufacturer for specific fireplace and type of gas being converted.

Warning: Correct operation of the system cannot be guaranteed if the conversion kit or valve have been dropped or sustained strong impact.

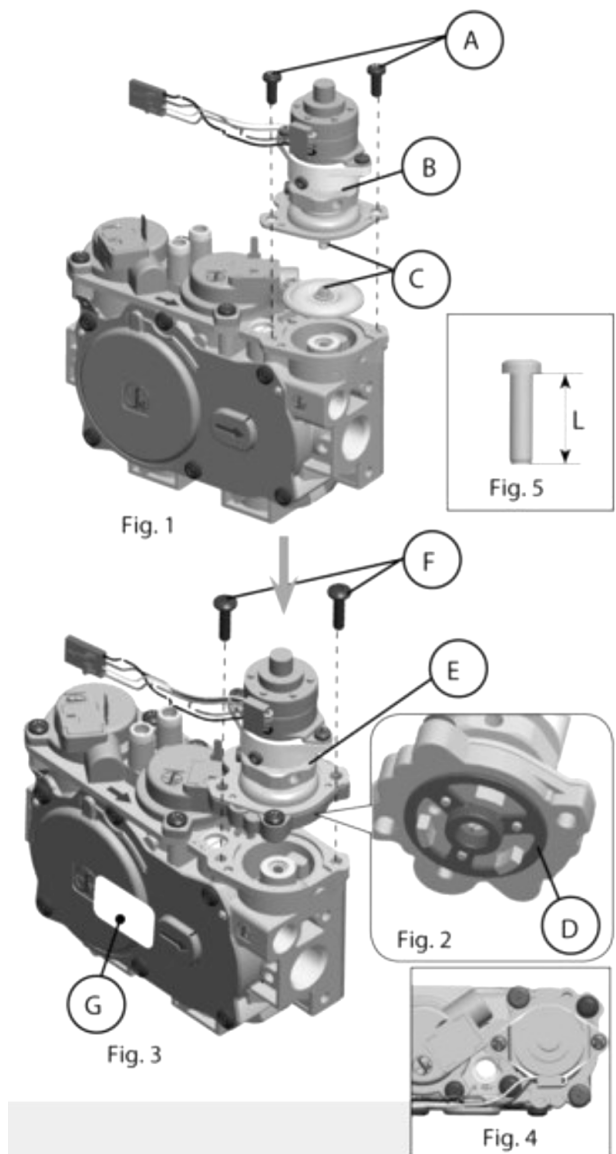

Figure 4-13 Pressure Regulator Conversion

4.4.3 Burner Ignition Characteristics

Note: Connect gas supply and verify that the minimum inlet and outlet pressures are conforming.

Once the conversion to LPG and all the above steps have been completed, light the main burners.

Use remote transmitter to turn on pilot light and burners. Main burner should now light IMMEDIATELY and flame should not "lift" off burner. If there is any delay in ignition or if flame is "lifting off" burner, turn off burner and carefully check for proper installation of logs/coins, vent system and proper pilot flame impingement on burner. Logs or coins must not block pilot flame or main burner flame. Vent system must be leak proof.

WARNING: Do not proceed with operation of this fireplace unless burner "cycles" on/off without delays!

4.4.4 Pilot Flame and Burner Relationship Verification

Prior to completing the LPG conversion process, the qualified service technician must light the pilot light and verify the relationship between the pilot light flames and the main burners. The pilot light flames directed towards the propagation ports on the rear and front burner must overlap the propagation ports on the burners.

The pilot light flames must be a minimum of 1" long and must overlap the propagation ports on both the rear and front burners as shown in the diagram, below. Verify that the burner tubes ignite quickly and the burner flames propagate smoothly along the entire length of the burners.

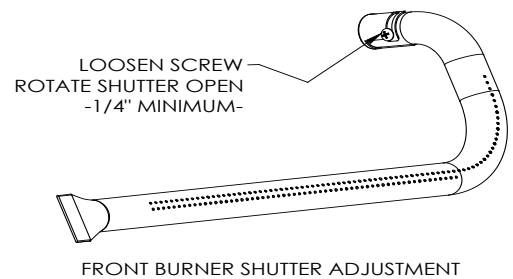
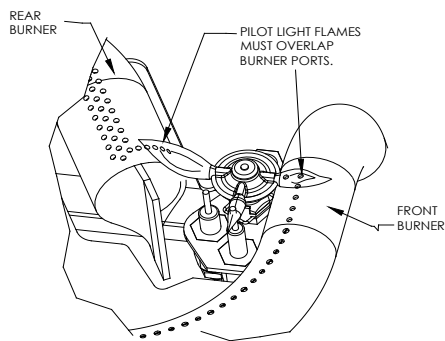

4.5 VENTING

WARNING: Proper installation of the vent system, as required in this manual, is vital to the performance of this Fireplace. Oversights or failure to conform to all installation requirements will void the applicable warranty.

The DXV35DT4 Fireplace must be vented vertically to the outside and must use a rigid coaxial ducting system.

This heater must be properly connected to a venting system in accordance with the manufacturer's installation instructions. Operation of this heater when not connected to a properly installed and maintained venting system can result in carbon monoxide (CO) poisoning and possibly death.

If the vent system of this appliance is disconnected for any reason, the vent and air intake systems must be properly reassembled and resealed before this appliance is put into use.

CAUTION: Each installation must conform to all local, state and national codes. Refer to the national fuel gas code and local zoning and code authorities for details on installation requirements. The Mendota Fireplaces must be vented to the outside in accordance with the latest edition of the National Fuel Gas Code. In the absence of local codes, the installation must conform with National Fuel Gas Code ANSI Z223.1 (NFPA 54), or Canadian Code CAN1-B149 or most current edition, also known as NFPA 54. Do not connect this Fireplace to a chimney flue serving a separate solid fuel or gas-burning appliance.

Do Not Use any silicone sealants at pipe joints. Stove gasket cements may be used at pipe joints but is not required.

4.5.1 Wall Thimble Information

A wall thimble is required to be installed when penetrating any combustible wall, regardless of whether the wall is an internal wall or an external wall.

Wall thimbles are designed to reduce the required clearances to the exterior surfaces of the vent pipe that pass through combustible walls. The hole size that is specified to be cut in the wall for installation of the wall thimble takes into consideration the reduced clearance requirement.

4.5.2 DXV35DT4 Master Venting Chart

If using a Mendota approved power vent kit, consult the power vent instruction manual for additional venting configurations.

Note: This chart is applicable to both natural gas and LP installations.

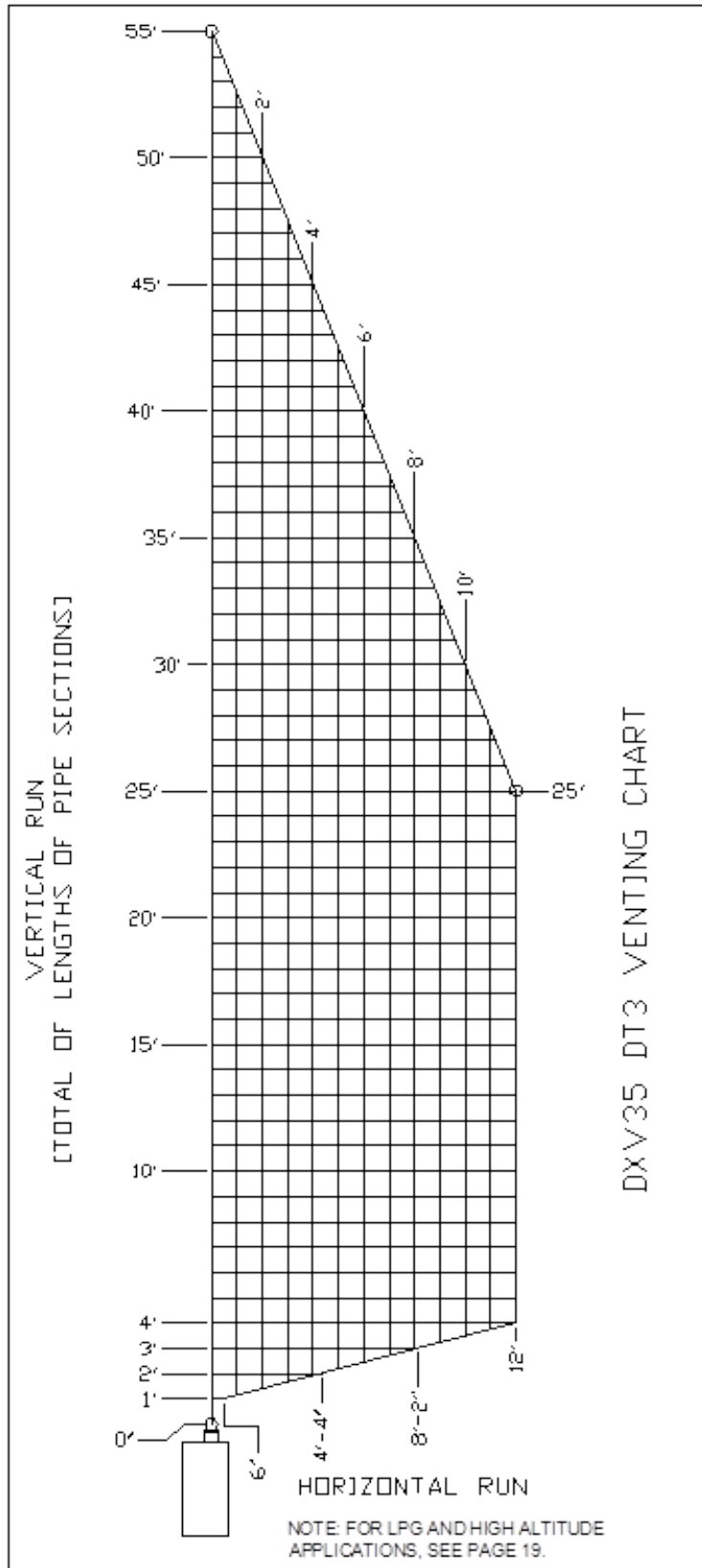

- 12" minimum vertical pipe run required to be connected directly to this fireplace's flue starter collar.
- Maximum horizontal run allowed with the minimum 12" vertical run is 6".
- Maximum vertical run allowed is 55'.
- Maximum vent system length allowed is 55'.
- 12' maximum horizontal run allowed with a minimum 4 to 25' starter section. Three 90° elbows may be installed anywhere within the 12' horizontal run. If the starter vertical section is less than 4', use the chart and reduce 3' for every 90° elbow installed after the first 90° elbow.

4.5.3 High Altitude Installation

Information

Prior to installing at altitudes higher than 7500, please contact the Mendota technical service department for specific venting requirements and venting restrictions.

4.5.4 Maximum Horizontal Run

- ❑ Maximum Horizontal Run allowed is 12 feet if a vertical starter section that is between 4 feet to 25 feet is connected directly to this fireplace's flue starter collar and no more than three (3) 90-degree elbows are used.
- ❑ Maximum Horizontal Run allowed is 12" if a 12" starter vertical section is connected directly to this fireplace's flue starter collar.

4.5.5 Maximum Vent System Length

- ❑ Combined total length of all straight pipe sections in the vent system shall be less than 55 feet.
- ❑ Combined total length of all straight pipe sections in the vent system shall be less than 55 feet when using three (3) 90-degree elbows or equivalent and terminating the vent system horizontally.

4.5.6 How to Calculate the Vent Lengths

For calculation purposes and usage of charts in this manual, simply add the lengths of all individual straight pipe sections. For example: if you use two 2-foot lengths and one 4-foot length, the total vent system length will be $2+2+4 = 8$ feet.

4.5.7 Using 90° Elbows

The DXV35DT4 Fireplace by MENDOTA allows maximum flexibility in the use of 90° elbows in the vent system. The length of the first straight vertical section directly connected to the fireplace's starter collar determines the maximum horizontal run and the number of 90° elbows allowed for this fireplace.

For vent systems that provide a starting vertical section that is 4' to 25', you may connect up to 12' of horizontal pipe and up to three 90° elbows.

4.5.8 Using 90° Elbows When the Initial Starter Vertical Section Is Less Than 4'

For vent systems that provide a starting vertical section less than 4' the following rules apply:

- A. You must use the Master Venting Requirements Chart.
- B. A single 90° vertical-to-horizontal elbow is already calculated into the allowable maximum horizontal run. The Venting Requirements Chart assumes that for all horizontal runs calculated, one 90° elbow is used within the venting system.

Note: Each additional 90° elbow reduces the maximum horizontal distance allowed by 3'.

- C. If you plan to use more than one 90° elbow within the vent system, first use the Venting Requirements Chart and calculate the maximum horizontal run you are allowed based on the first vertical section connected directly to the fireplace. From this maximum horizontal run calculated, subtract 3' for each additional 90° elbow you will use.

Caution: If a vertical-to-horizontal discharge elbow or a horizontal-to-horizontal discharge elbow is enclosed within a wall, floor or ceiling, a top air space clearance of 2" must be maintained above the entire body of the elbow.

4.5.9 Using 45-Degree Elbows

Two 45-degree elbows may be used in place of one 90-degree elbow. On 45-degree runs, one foot of diagonal pipe is equal to 8-1/2 inches horizontal run and 8-1/2 inches vertical run. Two 45-degree elbows may be connected directly to the vent starter adapter on this fireplace to create an offset to provide the required clearances to combustible framing or sheathing materials.

Two 45-degree elbows may be connected directly to the top of this fireplace to create a horizontal offset. 12 feet maximum horizontal run allowed with this offset configuration only if the first vertical section connected directly to the last 45-degree elbow is more than 4 feet to 25 feet long. For maximum allowable horizontal distances with the 45-degree offsets, see the Master Venting Configuration Chart.

Note: Each horizontally positioned 45° elbow reduces the maximum horizontal distance by 1½'.

SUPPORT: Horizontal runs of pipe will require one vent support for every 3 ft. of pipe.

4.5.10 Minimum Rise Horizontal Termination

The minimum vertical section required to be connected directly to the starter adapter on this fireplace is 12". With a 12" vertical starter section, a 6" horizontal run to a horizontal vent cap is allowed. If the total length of the vertical sections connected directly to the starter adapter on this fireplace is between 4' and 25', you are allowed a maximum 12' horizontal run. This fireplace provides a maximum flexibility in the use of 90° elbows when more than 4' of vertical starter section is connected to the starter collar. If 4' or more vertical section is connected to the starter collar, you may use three 90° elbows for horizontal terminations. For other venting configurations within these maximum limits, see Master Venting Chart.

Combined total length of all pipe sections in the vent system should be less than 44'.

NOTE: The horizontal run of vent pipe must be level or have a ¼" rise for every 1' of run toward the termination. Never allow the vent to run downward. This will cause high temperatures and the possibility of a fire.

Follow these steps to install venting:

1. Position fireplace in desired location. Check to determine if wall studs are in the way when vent system is attached. If this is the case you may want to adjust the fireplace location.
2. Locate where vent pipe will pass through any ceilings and will penetrate the outside wall. Since vent pipe sections "overlap," we suggest pre-assembling and measuring the total vent pipe run so you can more accurately locate the point where the vent pipe will penetrate the outside wall. Be sure all vent components are properly twist locked and leak-proof.
3. Cut and frame a 9" wide x 10" high opening in the outside wall openings and 9" x 9" opening in ceiling openings. The outside wall hole must be positioned so the vent system will have a ¼" rise per foot on horizontal runs and be perpendicular to the wall. The height of the opening must be located to meet all building codes and not allow the termination to be easily blocked or obstructed. A ceiling fire stop spacer is required at any floor (ceiling) opening.
4. The horizontal pipe must end flush with the exterior wall of the home. Horizontal pipe will require a proper support every 3' of vent pipe. **There must be a minimum of 1" clearance to combustibles from all vent pieces on the sides and bottom and 2" above horizontal runs.**
5. A wall thimble must always be used when penetrating combustible wall materials.
6. **Note:** Combustible wall thickness must be 4" to 8" maximum.

Note: Do not separate telescoping section. They be must be used as complete assemblies.

7. From the exterior of the home, slide the horizontal vent cap over the end of the horizontal pipe and tightly secure the vent cap to the wall with screws. Seal with high-quality caulking around the outer perimeter of the vent cap. **Note:** Vent cap shall not be recessed into wall or siding.

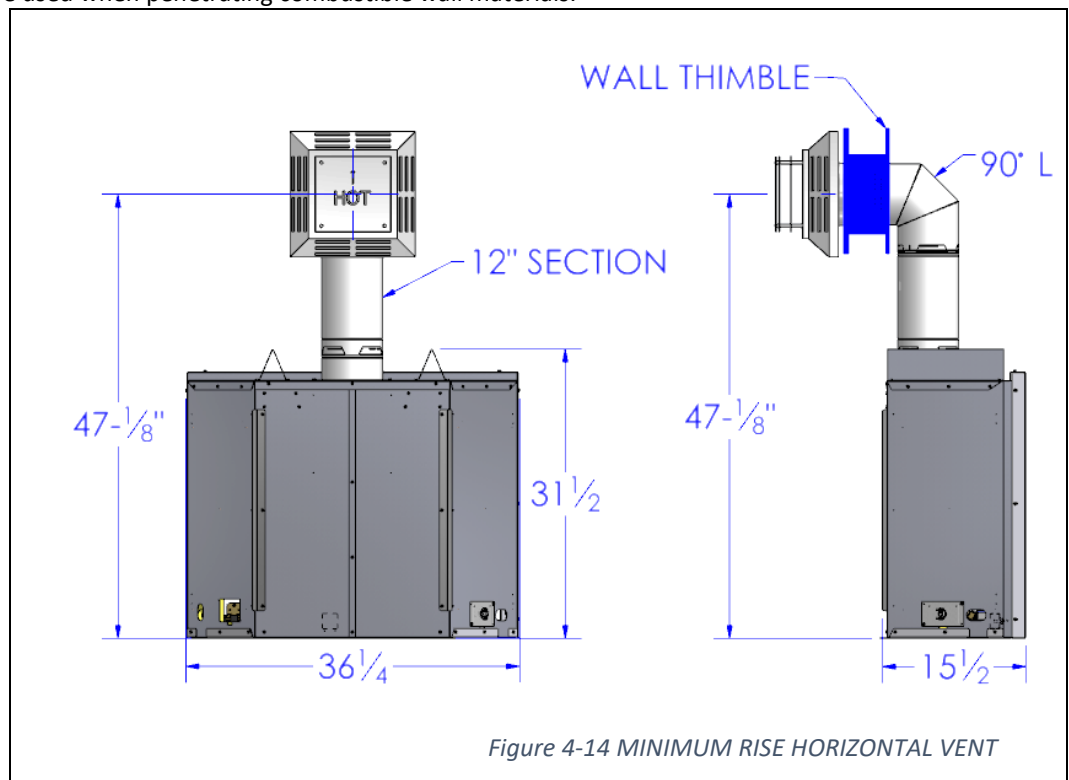

4.5.11 Elevated Vertical Rise Through-The-Wall Venting

The required MINIMUM vertical rise is 48 in. when used with a maximum horizontal run of 12 ft. For other venting configurations within these maximum limits.

NOTE: All horizontal runs of vent pipe must be level or have a ¼" rise for every 1' of run toward the termination. Never allow the vent to run downward. This will cause high temperatures and the possibility of a fire.

USING OFFSETS AND RETURNS: A single 90° vertical-to-horizontal elbow is already calculated into the allowable maximum 12' horizontal run. Each additional 90° elbow reduces the maximum horizontal distance by 3'. Example: by using three total 90° elbows the maximum horizontal distance has been reduced to 6 ft. (3 - 1 = 2 elbows x 3' = 6'; 12' Max. - 6' of elbows = 6' of horizontal run). Note: 45° elbows reduce the maximum horizontal distance by 1½'.

SUPPORT: Horizontal runs of pipe will require one vent support for every 3 ft. of pipe.

CAUTION: If a vertical-to-horizontal elbow is enclosed within a wall, floor or ceiling, a top air space clearance of 2" must be maintained above the elbow. Be sure to maintain 1" air space to any combustibles on the sides and bottom, 2" above horizontal pipe sections.

THIS FIREPLACE MUST BE INSTALLED BY A QUALIFIED MENDOTA APPROVED SERVICEPERSON.

1. Position fireplace in desired location. Check to determine if wall studs are in the way when vent system is attached. If this is the case you may want to adjust the fireplace location.
2. Locate the position where vent pipe will pass through any ceilings and will penetrate the outside wall. Since vent pipe sections "overlap" we suggest pre-assembling and measuring the total vent pipe run so you can more accurately locate the point where the vent pipe will penetrate the outside wall. Be sure all vent components are properly twist locked and leak-proof.
3. Cut and frame a 9-1/2" wide x 10" high openings in the outside wall openings and 9" x 9" opening in ceiling openings. The outside wall hole must be positioned so the vent system will run level or have a ¼" on rise AND be perpendicular to the wall. The height of the opening must be located to meet all building codes and not allow the termination to be easily blocked or obstructed. A ceiling fire stop spacer is required at all floor (ceiling) penetrations.
4. Connect vent pipe to the fireplace adapter on top of fireplace vent outlet.
5. The horizontal pipe must end flush with the exterior wall of the home. Horizontal pipes will require proper support every 3 ft. of vent pipe. **THERE MUST BE A MINIMUM OF 1" CLEARANCE TO COMBUSTIBLES ON THE SIDES AND BOTTOM OF ALL VENT PIECES (2" above horizontal runs and above elbows).**
6. A wall thimble must always be used when penetrating combustible wall materials.

NOTE: Combustible wall thickness must be 4" to 8" maximum for the wall thimble. Wall more than 8" thick will require special protection. Contact Mendota Technical services for assistance.

7. From the exterior of the home, slide the horizontal vent cap over the end of the horizontal pipe and tightly secure the vent cap to the wall with screws. Seal with high quality caulking.

WARNING: Venting terminal shall never be recessed into wall cladding or siding. Vent Cap must sit on top of siding or cladding.

4.5.12 Vertical Through-The Roof Venting

The maximum vertical run of vent pipe is 55 ft. from the top of the fireplace. The fireplace will support a run of a maximum of 55 ft. The vent system must be supported every 3 feet using Support Straps. Maintain 1" air space clearances on all sides of vent components that are positioned vertically and 2" above horizontal pipe sections and components.

THIS FIREPLACE MUST BE INSTALLED BY A QUALIFIED MENDOTA APPROVED SERVICEPERSON.

1. Place the fireplace in its desired location. Drop a plum bob from the ceiling to the position of the fireplace flue exit. Mark the location where the vent will penetrate the ceiling. Drill a small hole at this point. Next, drop a plum bob from the roof to the hole previously drilled in the ceiling. Mark and drill the spot where the vent will penetrate the roof. Determine if ceiling joists, roof rafters or other framing will obstruct the venting system. You may choose to relocate the fireplace or choose to offset the vent system to avoid cutting load bearing members.
2. Cut and frame a 9" x 9" opening in the ceiling centered on the hole drilled in Step 1.
3. To determine the length of the vent pipe required, measure the distance from the fireplace flue outlet to the ceiling, the ceiling thickness, and the vertical rise in the attic or second story and allow sufficient vent height above roofline. For two story installations, fire stops are required at each floor level. If an offset is needed in the attic, additional pipe and elbows will be required.
4. Assemble the desired lengths of vent pipe and elbows to reach from the fireplace flue outlet. Ensure that all vent pipe and elbow connections are in their fully twist-lock position and that inner pipe joints are sealed and are leak-proof. Maintain 1" airspace clearances to combustibles around vertical pipe sections and 2" clearance above horizontal run sections.
5. Cut a 9" x 9" opening in the roof, centered in the small drilled hole placed in the roof in Step 1. The opening should be a sufficient size to meet all clearance requirements. Continue to assemble lengths of pipe and elbows necessary to reach up through the roofline. Galvanized pipe and elbows may be utilized in the attic, as well as above the roofline. The galvanized finish is desirable above the roofline due to its higher corrosive resistance.
 - a. If an offset is necessary, it is important to support the vent pipe every 3 ft. to avoid excessive stress on the elbows and possible separation. Wall straps are available for this purpose.
 - b. Whenever possible, use 45° elbows instead of 90° elbows. The 45° elbow offers less restriction to the flow of flue gases and intake air. If a 90° elbow is necessary there must be a minimum of one pipe section rise between the 90° elbow and the vent cap. A maximum of three 90° elbows are allowed per installation.
6. Slip the flashing over the pipe sections protruding through the roof. Secure the base of the flashing to the roof with roofing nails and seal flashing to roof. Ensure the roofing material overlaps the top edge of the flashing. Verify you have at least the minimum clearance to combustibles at the roofline.
7. Continue to add pipe sections until the pipe and the vent cap meet the minimum building code requirements.
 - a. For multi-story vertical installation, a ceiling fire stop is required at the second floor and any subsequent floors. The opening should be framed to 9" x 9" inside dimensions as described in step No. 5.
 - b. Any occupied areas above the first floor, including closets and storage spaces, which the vertical vent passes through, must be enclosed. The enclosure may be framed and sheet rocked with standard construction materials, however, be sure to maintain minimum allowable clearances between the outside of the vent pipe and the combustible surfaces of the enclosure.
8. Height "*H" of top of vent cap can be determined as follows:
9. Complete installation with storm collar and vent cap.

ROOF PITCH	"H" DIMENSION	
	FEET	METERS
FLAT to 6/12	2	.6
7/12 to 9/12	2	.6
10/12 to 12/12	4	1.2
13/12 to 16/12	6	1.8
17/12 to 21/12	8	2.4

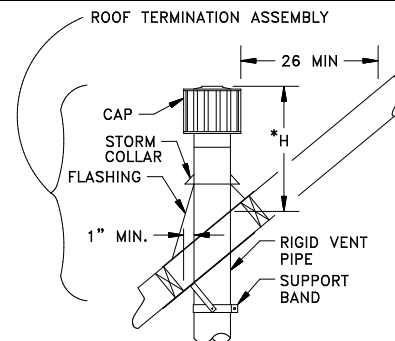

Height "*H" from roof surface to the top of vent cap can be determined as follows:

Complete installation with storm collar and vent cap.

4.5.13 Vent Damper Adjustments

This fireplace is equipped with a vent damper system that can be adjusted using the glass latch tool. Locate damper adjustment rod above the glass frame in convection chamber at the center. If this fireplace's vent is terminated horizontally, DO NOT CLOSE the vent damper completely. Adjust position of damper by judging the flame characteristics after 20 minutes of burn time. If the flames ghost off burners or if sooting occurs [in LPG units], open the vent damper FULLY and work backwards in increments to determine the correct damper position for that particular installation.

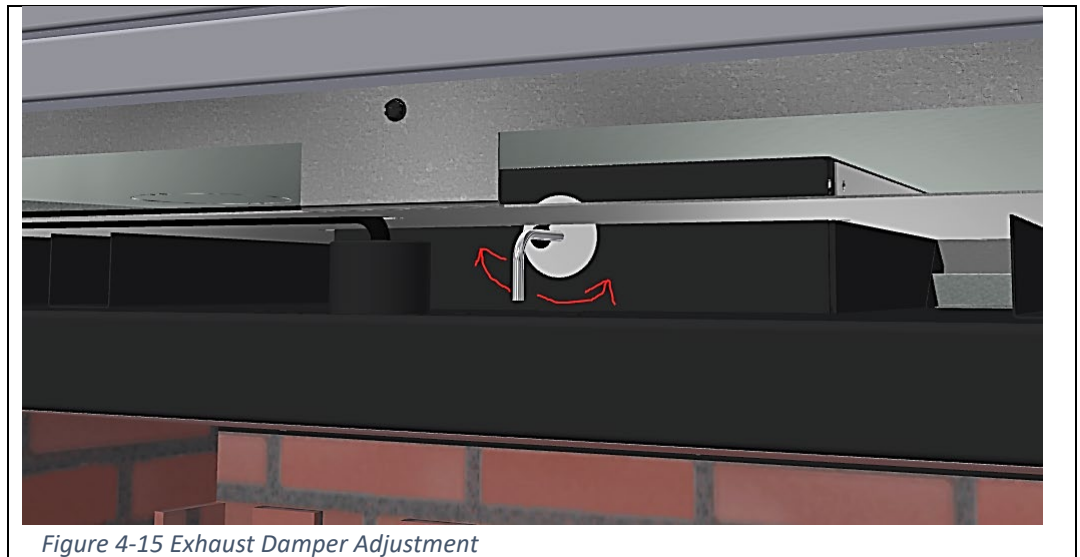

Figure 4-15 Exhaust Damper Adjustment

Look into the convection air cavity and note the Damper Position Indicator. Loosen damper base screw. Turn counter-clockwise to close the vent damper, tighten screw.

If this fireplace's vent is terminated horizontally, DO NOT CLOSE the vent damper completely.

4.6 POWER VENTING

4.6.1 VENT PIPE

For all installations rigid, coaxial vent pipe is required. 4" x 6 5/8" direct vent pipe must be used.

4.6.2 VENT STARTER HEIGHT REQUIREMENT

The vent adapter with a pressure tube must be connected to the fireplace starter collar. Installing the adapter results in a minimum vertical rise off the top of the fireplace. The adapter with the pressure tube is a 6" long vent. Minimum heights for venting from the top of the fireplace are shown in the drawing below.

ATTENTION: Vent pipe clearances to combustible material must be maintained to 3" above vent pipe and 1" on sides and bottom.

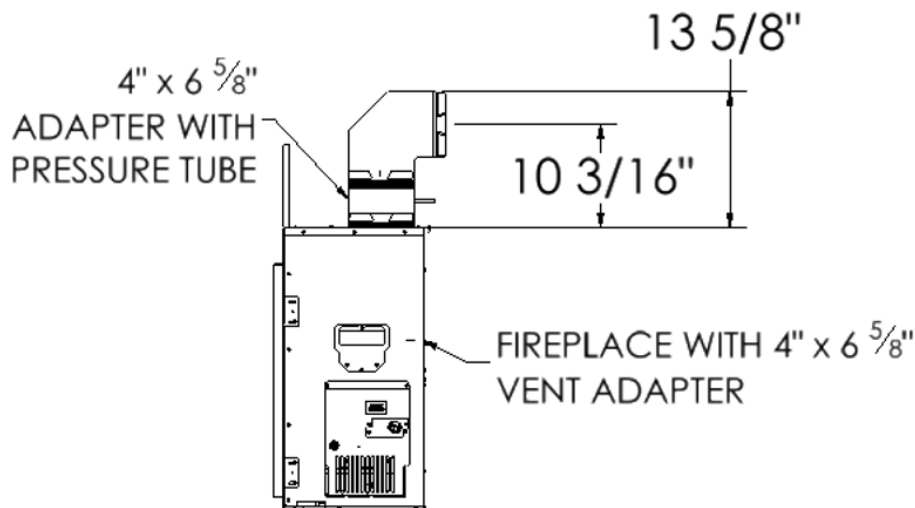

4.6.3 Approved Vent Systems

One of three power vents may be installed with this fireplace. Choose the correct power vent according to the required vent run. For detailed installation instructions follow the included with each power vent system.

- The fireplace may be vented using a Mendota approved power vent.
- The total vent length must be between 1' to 80' and can use up to 6 90° elbows or combination of other elbows equaling 90°.
- For horizontally terminated vent runs that are under 25 feet power vent kit AA-11-04071 must be used.
- For horizontally terminated vent runs that are over 25 feet power vent kit AA-11-04072 must be used.
- For vertically terminated vent runs use power vent kit AA-11-04100.

Reference the diagram below for approved venting configurations.

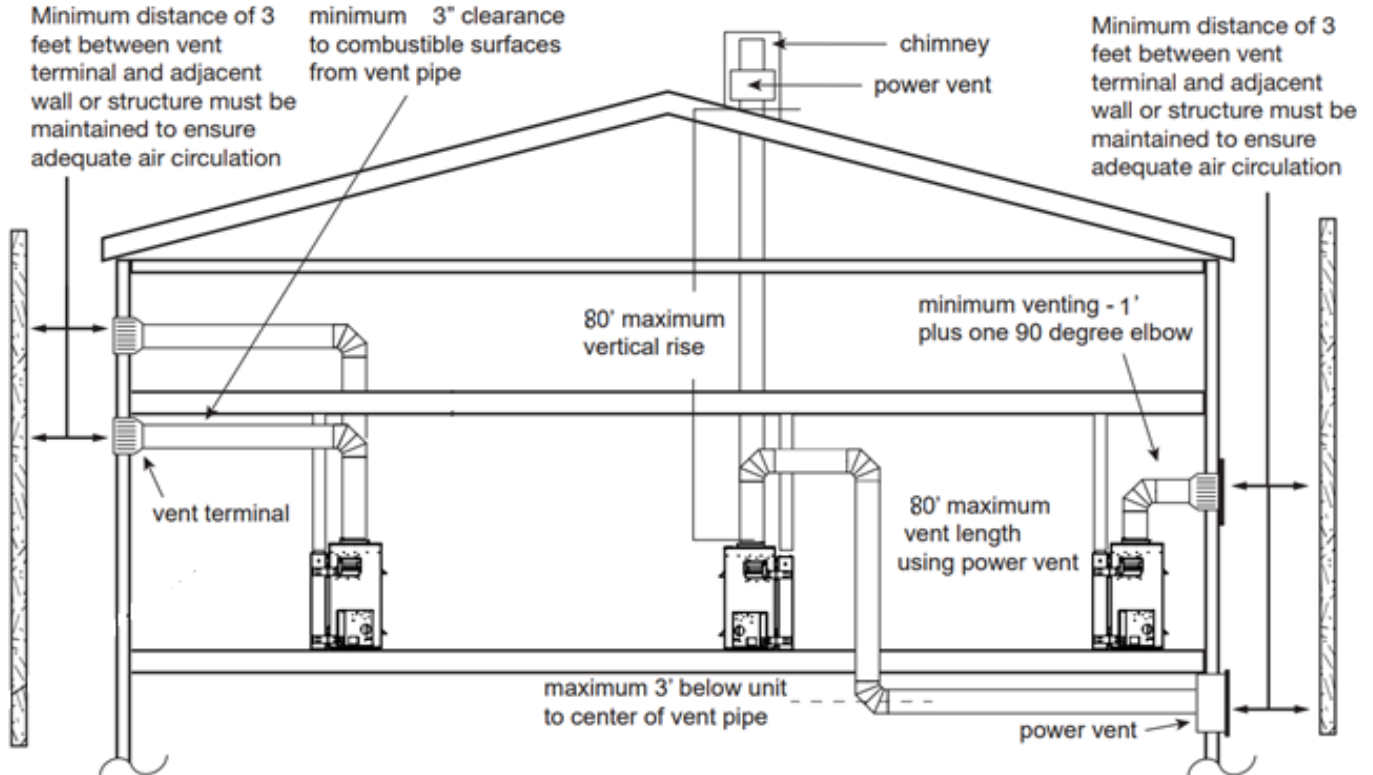

4.6.4 Power Vent Exterior Vent Locations and Restrictions

Note: All measurements are to be taken from the edge of the Power Vent.

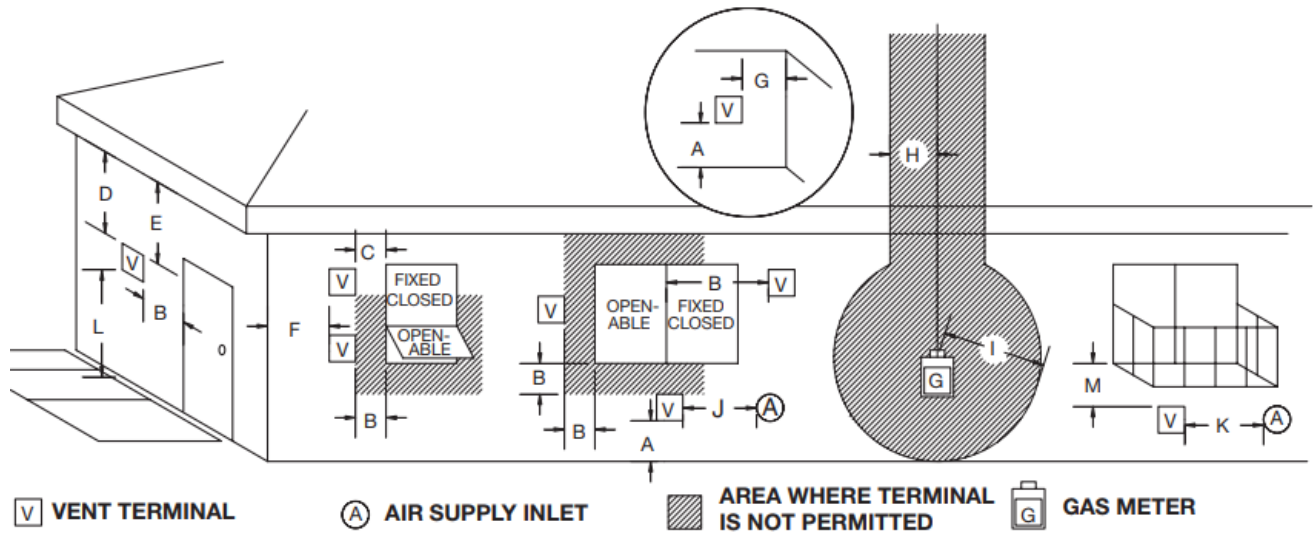

- A= clearances above grade, veranda, porch, deck, or balcony [* 12 inches (30 cm) minimum]
- B= clearance to window or door that may be opened [* 12 inches (30 cm) minimum]
- C= clearance to permanently closed window [minimum 12 inches (30 cm) recommended to prevent condensation on window]
- D= vertical clearance to ventilated soffit located above the terminal within a horizontal distance of 2 feet (60 cm) from the edge of the terminal [0 inches (0 cm) minimum]
- E= clearance to unventilated soffit [0 inches (0 cm) minimum]
- F= clearance to outside corner [6 inches (15 cm) minimum]
- G= clearance to inside corner [3 inches (7.5 cm) minimum]

- H= * not to be installed above a meter/regulator assembly within 3 feet (90 cm) horizontally from the center-line of the regulator
- I= clearance to service regulator vent outlet [* 6 feet (1.8 m) minimum]
- J= clearance to nonmechanical air supply inlet to building or the combustion air inlet to any other appliance [* 12 inches (30 cm) minimum]
- K= clearance to a mechanical air supply inlet [* 6 feet (1.8 m) minimum]
- L= ^ clearance above paved side-walk or a paved driveway located on public property [* 7 feet (2.1 m) minimum]
- M= clearance under veranda, porch, deck, or balcony [0 inches (0 cm) minimum**]

^ a vent shall not terminate directly above a side-walk or paved driveway which is located between two single family dwellings and serves both dwellings*

** only permitted if veranda, porch, deck, or balcony is fully open on a minimum of 2 sides beneath the floor*

* as specified in CGA B149 Installation Codes, Note: local Codes or Regulation may require different clearances

* for U.S.A. Installations follow the current National Fuel Gas Code, ANSI Z223.1

4.7 LOG SET/ MEDIA INSTALLATION

Three distinctive wood species log sets are available as options for this model Fireplace.

1. Norway Spruce Log Set
2. White Oak Log Set(not shown)
3. Birch Log Set
4. Premium Fiber Oak Log Set



Figure 4-16 Norway Spruce Logs



Figure 4-17 Birch Logs



Figure 4-18 Premium Fiber Oak Logs

Installation Instructions for each log set are included with the individual log set. Follow those instructions to install one log set.

Note: Installer, save and give the copy of the Log Set Installation Instructions to the homeowner for future references.

4.8 LIGHTING CHECKLIST

Be sure to check these items before final operation of the Fireplace.

- All items on "Installation Checklist" must be completed.
- Carefully follow all lighting and log installation instructions. Make certain that pilot flame lights immediately and lights both front and rear burners.
- Gas leaks and gas pressures prior to installing facing materials is checked.
- Fresh batteries are in remote control. Follow "First-Time Lighting Instructions" to synchronize the remote control and the ignition module.
- Air shutter opening 0" to 1/8" natural gas or 1/4" to 1/2" LP gas is checked.
- All lighting and log installation instructions were followed.
- Burners light immediately, and flame runs promptly around rear burner and lights entire burner.

Note: Do not proceed with operation unless burner cycles "on/off" without delays.

- Flame is "stable" and does not "lift" off burner. If flame lifts off burner, turn unit off and check that all vent pipes are "twist locked" and leak proof, the vent cap is "right side up". Do not proceed with operation if flame is "lifting off" burner.
- DO NOT proceed with operation unless burner cycles "on/off" without delays and the flame is "stable" and not "lifting" off burner after 5 minutes of initial ignition.

Caution: If ignition system goes into lockout mode, be sure to wait a minimum of five minutes before re-lighting.

4.9 AIR SHUTTER CONTROL AND FLAME APPEARANCE

During initial installation, the air shutter opening should be checked to be certain that the shutter is set correctly at 1/8" open for natural gas and 1/2" minimum open for L.P. gas. NOTE: For altitudes above 5,000', some variations may be required.

Be sure burner and logs are properly installed. After log set has been properly installed, adjustments to the air shutter shall be made for final flame appearance. These small shutter adjustments can be made by the following procedure:

NOTE: All adjustments to the air shutter setting must be made by a qualified installer, service agency, or the gas supplier. Very small changes in shutter settings make major changes in flame appearance.

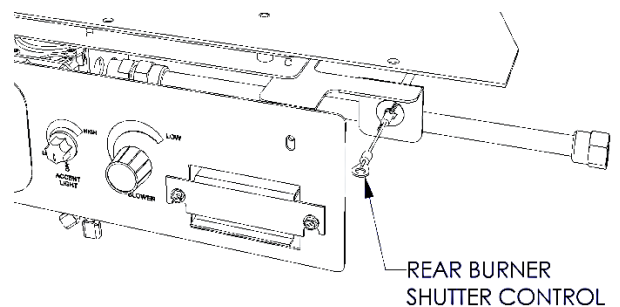

Figure 4-19 Burner Air Shutter Controls

The rear burner air shutter adjustment cable is located on the right side of the courtesy panel. To open or close the air shutter insert the glass latch tool tip in the ring terminal's ring hole. **Push the cable to close the air shutter or pull on the cable to open the air shutter.**

1. If flame is too blue, close air shutter in small 1/8" increments until flame turns desired realistic yellow. Use glass latch tool to hook end and slide control.
2. If flame is causing soot on viewing glass, open air shutter fully until sooting stops. Continue burning unit with air shutter fully open for four to six hours until all internal deposited soot has burned off.
3. Once deposited soot has disappeared, close air shutter in increments of 1/8".

LPG Air shutter settings hint: A properly adjusted air shutter setting will yield burner flames that have an approximate 2" high blue color base. If yellow colored flames are starting at burner level, air shutter is closed too far and will create soot. If you observe that the flame is yellow starting very close to or at the burner surface level, open air shutter. Also, if a log or part of a log is suspended and hanging inside a yellow portion of the flame, soot can form easily on the part of the log that is inside the yellow flame area.

IMPORTANT: Try each new shutter setting approx. 1/2 hr. before making additional changes. NOTE: Changes in front burner flame can be made by re-arranging the coals and front burner air shutter opening.

5 HOMEOWNER INFORMATION

Welcome to Mendota. We are proud to be the makers of world-class direct vent fireplaces and Fireplaces. We understand that a fireplace is a long-term investment, and we are happy you have chosen us to be a part of your family. We are committed to quality and satisfaction for all Mendota owners. Thank you for choosing a Mendota to be a source of comfort and beauty in your home.

We have designed this manual to help you enjoy all that your Mendota Fireplace has to offer. You will find tips, operating instructions, and frequently asked questions to support the features and functions of your Fireplace.

We want you to enjoy your Mendota for years to come. If you have any additional questions regarding operation of your Fireplace, please contact your Mendota local dealer.

5.1 AESTHETIC CONSIDERATIONS

Burning or static fireplaces are a major aesthetic focus in any room. In addition to offering the most realistic log details, textures, coloration and the most realistic wood fire options, Mendota also offers a large array of internal firebox lining options and external decorative options. Visit www.mendotaearth.com and your local Mendota dealer's show room to view all options available.

5.2 HEATING PERFORMANCE

Mendota's high heat output Fireplace will heat a large area of your home. Air movement options for maximizing heat circulation that can be considered are operating the Fireplace's convection blowers, continuous operation of central heating furnace blowers or room ceiling fans. The heat output of the fireplace can be reduced by turning off the Rear Burner and reducing flame height using the remote control. Blowers can be turned down or turned off to reduce heat distribution.

5.3 IMPORTANT INFORMATION FOR HOMEOWNER

Before you begin operation of your Gas Fireplace Heater, read and familiarize yourself with information provided in the following chapters of this manual:

5.3.1 Using Your Remote Control

Your Mendota remote control is pre-programmed to your fireplace. Ensure you have installed 3 AAA batteries into your remote.

Press the top button on the remote control. If you do not hear a beep when you press this button, follow the instructions below to synchronize your fireplace and remote control.

5.3.2 Synchronizing the Fireplace and Remote Control

Note: The master switch and sync switch are located at the bottom behind the lower grill.

Master Switch The master switch acts as the main safety on/off control for the main gas burners only. When the master switch is in the off-condition, the main gas burners will not turn on. However, all other fireplace functions, including the Continuous Pilot Mode (CPI), will operate. When the master switch is in the on-condition, the main burners will function as designed.

In case of an emergency, toggle the master switch to off to turn off the main burners.

To synchronize the fireplace and remote control, follow the steps below:

1. Toggle the **master switch** to "on" (toggle up).
2. Locate **sync switch** (above master switch in the right-side air gap). Press the sync button and release. The fireplace will **beep three times** indicating that it is ready to synchronize with a remote control. (Note: If you do not hear any beeps when you press the sync button, contact your Mendota dealer or installer for assistance.)
3. Within seven seconds, press the "on" button on the remote control. The fireplace will **beep four times** to indicate that the remote control's command is accepted and sets to the particular code of that controller.

Your system is now initialized.

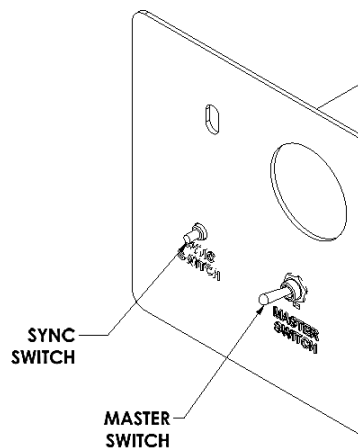

5.3.3 Remote Control Functions

NOTE: You will hear an audible beep once every time a remote-control button is pressed, signaling that the command has been received. If you do not hear the beep, press the button again.

Locate the four function buttons on the remote control:

1. **On/Off Button:** This button turns the fireplace on or off. When this button is pressed and the system is off, the pilot will ignite. After pilot ignition, the pilot will light the main burners. Refer to IPI and CPI Modes in this manual for pilot ignition.
2. **Thermostat Button:** This button will allow the selection of three modes: Manual, Normal Thermostat, and Smart Thermostat.
 - a. **Manual (Off):** In this mode, the fireplace can be turned on, regardless of the room temperature. The actual room temperature has no effect in this mode. All other functions such as fan speed control, flame height control, secondary burner on/off control and accent light intensity controls are manually controlled.

WARNING: Do not leave this appliance burning and unattended for long periods in the manual(off) mode. Leaving the appliance burning in manual (off) mode for long periods can lead to overheating of the living space which can negatively affect plants, animals, infants and vulnerable people.

Note: In Manual Mode, the fireplace will automatically shut off after 12 hours of continuous use. In Normal Thermostat and Smart Thermostat modes, if the fireplace does not receive a prompt from the remote-control transmitter for 60 minutes, the fireplace will automatically shut off. This can occur if the remote control is moved to another room or if the remote batteries are very weak.

- b. **Normal Thermostat (On):** In this mode, the fireplace will turn itself on and off, depending on the temperature you set. When you set the fireplace thermostat, the fireplace will stay functioning until the room temperature increases 1°F above the set thermostat temperature. To increase the thermostat temperature, press the up button until the desired temperature is displayed in the thermostat temperature window. The fan will turn on five minutes after fireplace startup and will turn off 12-1/2 minutes after the flames turn off, in this mode. The flame height can be adjusted while the fireplace is functioning, fan speed can be adjusted after five minutes of startup. Rear burner can be turned on or off at any time after startup. The accent light can be adjusted any time after startup.
 - c. **Smart Thermostat (Smart):** In this mode, room temperature is maintained and flame height adjusts automatically to provide continual, efficient heat. All other functions of the normal thermostat mode, except the flame height adjustment, are allowed. Manual flame height adjustment is not allowed in this mode. The Smart Thermostat function adjusts the flame height in accordance to the difference between the set point temperature and the actual room temperature. As the room temperature gets closer to the set point temperature, the Smart Thermostat automatically modulates the flame down.
3. **Up/Down Button:** This button is used to increase or decrease the thermostat temperature, flame height, fan speed, and accent light intensity. This also controls the rear burner on/off.
 4. **Mode Selection Button:** This button is used to toggle between the various function icons: flame height, fan speed, accent light, and rear burner.

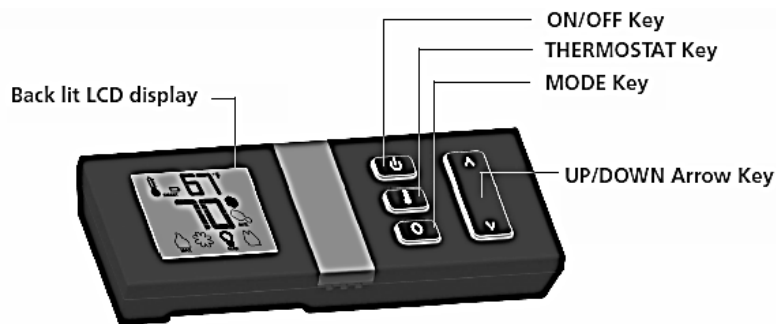

Figure 5-1 Remote Control Buttons

**Thermostat
Off/On/Smart**

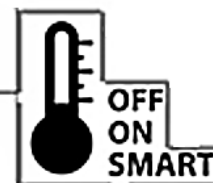

Figure 5-2 Display Modes

5.4 REMOTE CONTROL OPERATING INSTRUCTIONS

5.4.1 To Turn on the Fireplace

NOTE: If the fireplace does not respond to the remote-control commands, the fireplace system may have entered “safety lockout” mode. To reset the system, see [Chapter 5.10.12 Why won't my fireplace turn on?](#)

1. Press the on/off button. The remote-control display will show all active icons on the screen.
2. Select the thermostat mode by pressing the thermostat button: OFF (meaning Manual), ON (meaning Normal Thermostat) or Smart (meaning Smart Thermostat).
 - a. If the thermostat icon displays as “OFF” (Manual), the fireplace will ignite and start on Hi.
 - b. If the thermostat icon displays as “ON” (Normal Thermostat), the fireplace will only ignite if the thermostat temperature is greater than the room temperature.
 - c. If the thermostat icon displays as “SMART” (Smart Thermostat), the fireplace will only ignite if the thermostat temperature is greater than the room temperature.

5.4.2 To Turn off the Fireplace

Press the on/off button.

5.4.3 Understanding Your Remote-Control Icons

Your remote control displays and controls the following functions. See below for detailed control explanations.

Note: the “AUX On” function is not used in this fireplace.

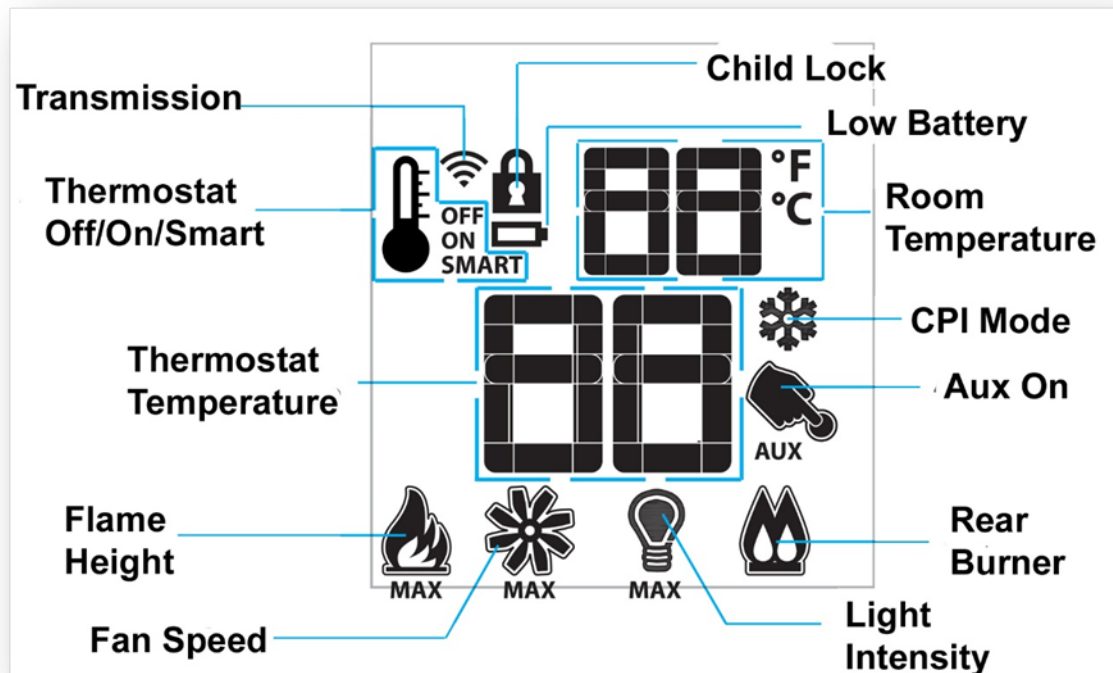

Figure 5-3 Remote Control Icons

5.4.4 Icon Details



Mode Button: Pressing the mode button toggles between the various available functions: flame height, fan speed, accent light intensity and rear burner on/off.



FLAME HEIGHT

Flame Height: Six flame height levels are available. While the flame height icon is displayed, pressing the up or down button once will increase or decrease the flame height by one of six increments.

If the flame height is at Level one and the down button is pressed, all burners will turn off.

If in IPI mode, the pilot will also extinguish.

If in CPI mode, the pilot will remain on.

Note: If in Smart Thermostat, the flame height function is not available for manual adjustment.

In Smart Thermostat, the flame height regulates automatically.

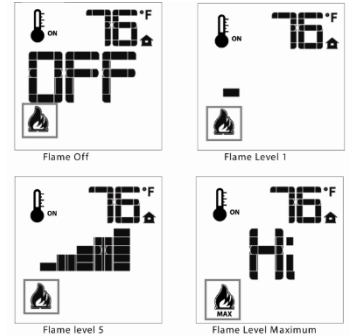

FAN SPEED

Fan Speed Control: The fan speed can be adjusted through six speeds and off. To activate this function, press the Mode button until it displays the fan icon. Use the up/down arrow button to turn on, off, or adjust the fan speed. Once you set the desired fan control, the system will remember your selected fan speed until you manually change it.

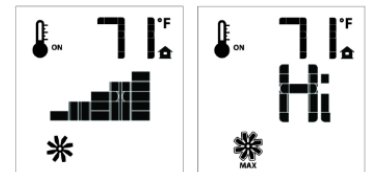

Accent Light: This function controls the accent light functions. Pressing the UP button in this mode will turn on the accent light and allow you to control the 6 levels of intensity. Once you set the desired light intensity, the system will remember your selection until you manually change it.

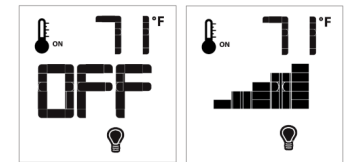

2nd BURNER

Rear Burner: This function controls the rear burner on/off feature. Pressing the up button in this mode will turn on the rear burner and pressing the down button will turn off the rear burner. The flame height of the front burner will not change when you turn the rear burner on or off. The flame height can only be changed in the Flame Height mode.

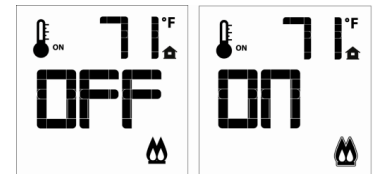

5.5 IPI AND PILOT ON DEMAND MODES

Intermittent Pilot and Pilot on Demand Features

This gas fireplace is equipped with an electronic ignition system that first lights a pilot then uses the pilot to ignite the main burners. The pilot can be set in the CPI (Pilot on Demand) mode to allow the pilot to remain on for 7 days before timing out by setting the remote control to CPI mode. If the remote control is set to the IPI (Intermittent Pilot Ignition) mode, the pilot will only light and remain ON while the main fireplace burners are operating.

IPI Mode: This mode turns the pilot off when the fireplace is not functioning and only lights the pilot automatically when a call for heat is made by the remote control.

CPI Mode: If set to CPI mode, the pilot will ignite and remain on for a time of 7 days of inactivity before shutting off. Each time the fireplace is used the 7-day clock will reset.

5.5.1 Setting to IPI or CPI mode

With the remote control OFF, press the MODE button. You will see either “CPI” or “IPI” displayed on the screen. Press the Up-arrow button to set “CPI” mode and press the DOWN arrow button to set “IPI” mode. Once set to the desired setting, press ON/OFF button to activate the fireplace.

Note: The snowflake icon will be visible on the display at all times when in CPI mode.

Recommended: Mendota recommends that **CPI mode is used during the winter months** when the average daily high temperature falls below 50°F. This will keep the fireplace chimney heated for proper updraft during burner ignition, and it will also eliminate excessive condensation of exhaust vapors on the door glass. Leaving the fireplace in CPI mode will keep the fireplace body warm and eliminate cold drafts and heat loss to the cold air that is trapped inside the firebox.

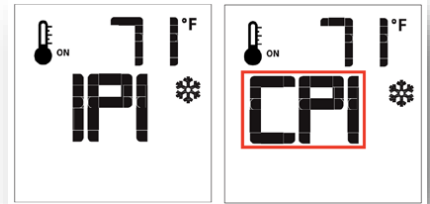

5.6 HOW DO I CHANGE FROM CELSIUS TO FAHRENHEIT?

To change between °C to °F, follow these steps:

1. Press the ON/OFF button and turn off the fireplace.
2. Simultaneously, press both the mode button and the thermostat button.
3. Look at the LCD display to verify that your desired indicator (°F or °C) is being displayed.

If not, repeat Step 2.

5.7 First Time Lighting Instructions

Warning: If you do not follow these instructions exactly, a fire or explosion may result causing property damage, personal injury, and loss of life.

WHAT TO DO IF YOU SMELL GAS

Do not light any appliance.

Do not touch any light switch

Do not use any phone in your building.

Call your gas supplier from a neighbor's phone.

Follow the provider representative's instructions.

If you cannot reach your gas supplier, call the fire department for assistance.

5.7.1 Safety Information

- This fireplace is equipped with an ignition device which automatically lights the pilot. Do not attempt to light pilot by hand.
- **Before operating**, smell all around fireplace area for gas. Be sure to smell next to the floor because some gas is heavier than air and will settle on the floor.
- Toggle Master Switch to **ON**. Remote control will not communicate to receiver unless the Master Switch is **ON**.
- Use only the supplied remote control to light the pilot. This valve will not operate if the pilot is not lit and stable.
- Do not use this fireplace if any part has been underwater. Immediately call a qualified service technician to inspect and replace any component which has been under water. Attempted operation may result in fire or explosion resulting in property damage, personal injury, and loss of life.

5.8 OPERATING INSTRUCTIONS

1. Read the above safety information carefully before proceeding.
2. Do not attempt to light the pilot by hand; the door must remain on this unit during pilot ignition, except for the "First Time Lighting".
3. Press the ON/OFF button on remote control to begin the ignition sequence.
4. The fireplace will emit an audible beep then the igniter will begin to spark. After the pilot lights and is established, the valve will automatically open and the burner will light. The burner will initially light to full flame. Adjust it to an appealing setting with the remote. See Remote Operating Instructions in Operating Instructions Manual.
Warning: If the pilot fails to light, the system will "lockout". Press ON/OFF button on remote control to Turn Off the system and reset the "lockout". Allow five minutes for any gas in the unit to dissipate before attempting to re-light the pilot.
5. Press ON/OFF button on remote control again to start ignition sequence.
6. If the fireplace will not operate, follow the instructions "To Turn off Gas to Fireplace" below and call your service technician or gas supplier.

5.9 TO TURN OFF GAS TO FIREPLACE

1. Press the ON/OFF button on the remote control.
2. Turn off CPI Pilot Mode from remote control.
3. Turn off the internal manual shutoff valve in the appliance.
4. Turn OFF the external manual shutoff valve if was required and supplied by installer and mounted adjacent to fireplace.
5. Turn OFF all electric power to the fireplace if service is to be performed.

5.10 FREQUENTLY ASKED QUESTIONS

5.10.1 What to do if I smell gas?

If you smell gas:

- Do not light any appliance.
- Do not touch any light switches.
- Do not use any phone in your building.
- Call your gas supplier from a neighbor's phone.
- Follow the provider representative's instructions.
- If you cannot reach your gas supplier, call the fire department for assistance.

5.10.2 Where can I find the model and serial numbers?

When requesting service, you will be asked to provide the **model number** and **serial number** to your Mendota dealer. This information will expedite the warranty verification process. The Listing Label contains the model number and serial number for your particular appliance.

This is an example of your listing label:

Listing label location: The listing label is located in the air gap below the bottom edge of the glass door frame. It is attached to a cable and can be pulled out to be viewed.



MENDOTA
NORTH AMERICA'S LUXURY FIREPLACE



Intertek
W/N 20784

DIRECT VENT GAS FIREPLACE HEATER
(POELE AU GAZ HOMOLOGUÉE, À AÉRATION DIRECTE)
NOT FOR USE WITH SOLID FUEL
(NE DOIT PAS ÊTRE UTILISÉ AVEC UN COMBUSTIBLE SOLIDE)

MANUFACTURED BY (FABRIQUÉ PAR):
JOHNSON GAS APPLIANCE CO. HIAWATHA, IOWA
CERTIFIED FOR CANADA (HOMOLOGUÉ POUR LE CANADA)
CERTIFIED TO (CERTIFIÉ) ANSI Z21.88-2019(R2024) • CSA
2.33-2019(R2024) CATEGORY II APPLIANCE

⚠ DANGER

HOT GLASS WILL CAUSE BURNS.
DO NOT TOUCH GLASS UNTIL COOLED.
NEVER ALLOW CHILDREN TO TOUCH GLASS.

VITRE CHAUDE - RISQUE DE BRÛLURES.
NE TOUCHEZ PAS UNE VITRE NON REFRIGÉE.
NE LAISSEZ JAMAIS UN ENFANT TOUCHER LA VITRE.

A barrier designed to reduce the risk of burns from the hot viewing glass is provided with this appliance and must be installed for the protection of children and other at-risk individuals.
L'écran pare-éclats fourni avec ce foyer réduit le risque de brûlure en cas de contact accidentel avec la vitre chaude et doit être installé pour la protection des enfants et des personnes à risques.

Refer to the Intertek Directory of Building Products (<https://bpdirectory.intertek.com>) for detailed information.
Consultez l'Intertek Directory of Building Products (<https://bpdirectory.intertek.com>) pour des informations

WARNING: IMPROPER INSTALLATION, ADJUSTMENT, ALTERATION, SERVICE OR MAINTENANCE CAN CAUSE PROPERTY DAMAGE, PERSONAL INJURY, OR LOSS OF LIFE. REFER TO THE OWNER'S INFORMATION MANUAL PROVIDED WITH THIS APPLIANCE. INSTALLATION AND SERVICE MUST BE PERFORMED BY A QUALIFIED INSTALLER. THIS VENTED GAS APPLIANCE IS NOT FOR USE WITH AIR FILTERS. OPTIONAL REGISTER KIT'S AA-11-04732, AA-11-04734 AND AA-11-00390 MAY BE USED. OPTIONAL POWER VENTS AA-11-04071, AA-11-04072 AND AA-11-04100 MAY BE USED. FOR USE ONLY WITH GLASS BARRIER Part no. AA-11-02020

MISE EN GARDE: IMPROPRE INSTALLATION, UN RÉGLAGE, UNE MODIFICATION, UN ENTRETIEN OU UN ENTRETIEN INCORRECTS PEUVENT CAUSER DES DOMMAGES MATÉRIELS, DES BLESSURES CORPORELLES OU LA MORT. REPORTEZ-VOUS AU MANUEL D'INFORMATION DU PROPRIÉTAIRE FOURNI AVEC CET APPAREIL. L'INSTALLATION ET L'ENTRETIEN DOIVENT ÊTRE EFFECTUÉS PAR UN INSTALLATEUR QUALIFIÉ. CET APPAREIL À GAZ VENTILÉ N'EST PAS DESTINÉ À ÊTRE UTILISÉ AVEC DES FILTRES À AIR. LES KITS D'ENREGISTREMENT OPTIONNELS AA-11-04732, AA-11-04734 ET AA-11-00390 PEUVENT ÊTRE UTILISÉS. LES ÉVÉNEMENTS ÉLECTRIQUES AA-11-04071, AA-11-04072 ET AA-11-04100 PEUVENT ÊTRE UTILISÉS EN OPTION. À UTILISER UNIQUEMENT AVEC UNE BARRIÈRE EN VERRE N° de pièce AA-11-03777

WARNING: DO NOT OPERATE THE APPLIANCE WITH GLASS FRONT REMOVED, CRACKED OR BROKEN. REPLACEMENT OF THE PANEL(S) SHOULD BE DONE BY A LICENSED OR QUALIFIED SERVICE PERSON. FOR USE WITH GLASS DOORS CERTIFIED WITH THE APPLIANCE ONLY.

AVERTISSEMENT: NE PAS UTILISER L'APPAREIL SI LE PANNEAU FRONTAL EN VERRE N'EST PAS EN PLACE, EST CRAQUÉ OU BRISÉ. CONFIEZ LE REMPLACEMENT DU PANNEAU À UN TECHNICIEN AGRÉÉ. SEULES DES PORTES CERTIFIÉES POUR CET APPAREIL DOIVENT ÊTRE UTILISÉES.

	<input type="checkbox"/> NATURAL GAS (GAS DE PÉTROLE)	<input type="checkbox"/> LP GAS (GAZ NATUREL LIQUÉFIÉ (GPL))
INPUT RATING (BTR/HR) 0-2000ft (0-610m) (ENTRÉE NOMINALE)	33,000	33,000
MIN. INPUT RATING (BTU/HR) 0-2000ft (0-610m) (MINIMALE ENTRÉE NOMINALE)	10,000	13,000
ORIFICE 0-2000ft (0-610m) (FRONT/REAR)	#49/#44	3/64"/3/64"
ORIFICE 2000-4500ft (610-1370m) (FRONT/REAR)	#49/#45	3/64"/#55
INPUT RATING (BTU/HR) 2000-4500ft (610-1370m)	28,333	28,061
MAXIMUM OUTPUT (BTU/HR) (SORTIE MAXIMALE)	24,057	23,974
MANIFOLD PRESSURE (in. w.c./kPa) (PRESSION AU COLLECTEUR)	3.5 (0.87)	10.0 (2.5)
MANIFOLD PRESSURE, LOW (in. w.c./kPa) (PRESSION AU COLLECTEUR MINIMALE)	1.6 (0.4)	6.4 (1.59)
MINIMUM INLET PRESSURE (in. w.c./kPa) (PRESSION D'ENTRÉE MINIMALE)	5.0 (1.24)	11.0 (2.74)

THIS APPLIANCE IS ONLY FOR USE WITH THE TYPE OF GAS INDICATED ON THE RATING PLATE AND MAY BE INSTALLED IN AN AFTERMARKET, PERMANENTLY LOCATED, MANUFACTURED HOME (USA ONLY) OR MOBILE HOME, WHERE NOT PROHIBITED BY LOCAL CODES. SEE OWNER'S MANUAL FOR DETAILS. THIS APPLIANCE IS NOT CONVERTIBLE FOR USE WITH OTHER GASES, UNLESS A CERTIFIED KIT IS USED.

CET APPAREIL DOIT ÊTRE UTILISÉ UNIQUEMENT AVEC LE TYPE DE GAZ INDIQUÉ SUR LA PLAQUE SIGNALÉTIQUE. CET APPAREIL PEUT ÊTRE INSTALLÉ DANS UNE MAISON PRÉFABRIQUÉE OU MOBILE (É.-U. SEULEMENT) INSTALLÉE À DEMEURE SI LES RÉGLEMENTS LOCAUX LE PERMETTENT. VOIR LA NOTICE DE L'UTILISATEUR POUR PLUS DE RENSEIGNEMENTS. CET APPAREIL NE PEUT PAS ÊTRE UTILISÉ AVEC D'AUTRES GAZ SAUF SI UNE TROUSSE DE CONVERSION CERTIFIÉE EST FOURNIE.

MINIMUM CLEARANCES TO COMBUSTIBLE CONSTRUCTION		
UNIT TO FLOOR	0 in.	GLASS EDGE TO ADJACENT SIDEWALL 12 in.
UNIT TO ENCLOSURE SIDEWALL	1/2 in.	VENT PIPE TOP TO COMBUSTIBLES 2 in.
UNIT TO ENCLOSURE BACK WALL	1/2 in.	VENT PIPE SIDES TO COMBUSTIBLES 1 in.
UNIT BOTTOM TO ENCLOSURE CEILING	53-3/8 in.	VENT PIPE BOTTOM TO COMBUSTIBLES 1 in.
UNIT FLOOR TO ROOM CEILING	72 in.	8" MANTLE ABOVE DISCHARGE AIR OPENING 14 in.

DÉGAGEMENTS MINIMAUX PAR RAPPORT AUX MATÉRIEAUX COMBUSTIBLES		
UNITÉ AU PLANCHER	0 MM	BORD DU VITRAGE AU MUR LATÉRAL ADJACENT 305 MM
UNITÉ AU MUR LATÉRAL DE L'ENCEINTE	13 MM	DESSUS DU CONDUIT AUX MATÉRIEAUX COMBUSTIBLES 50.8 MM
UNITÉ AU MUR ARRIÈRE DE L'ENCEINTE	13 MM	CÔTÉS DU CONDUIT AUX MATÉRIEAUX COMBUSTIBLES 25 MM
DESSOUS DE L'UNITÉ AU PLAFOND DE L'ENCEINTE	1360 MM	DESSOUS DU CONDUIT AUX MATÉRIEAUX COMBUSTIBLES 25 MM
PLANCHER DE L'UNITÉ AU PLAFOND DE LA PIÈCE	1830 MM	MANTEAU DE 8 PO AU-DESSUS DE LA SORTIE D'AIR 356 MM

CAUTION: HOT WHILE IN OPERATION. DO NOT TOUCH. KEEP CHILDREN, CLOTHING, FURNITURE, AND FLAMMABLE LIQUIDS OR VAPORS AWAY. KEEP GASOLINE AND OTHER LIQUIDS HAVING FLAMMABLE VAPORS AWAY. KEEP BURNER AND CONTROL COMPARTMENT CLEAN. SEE INSTALLATION AND OPERATING INSTRUCTIONS ACCOMPANYING APPLIANCE.

ATTENTION: L'APPAREIL EST CHAUD LORSQU'IL FONCTIONNE. NE PAS TOUCHER L'APPAREIL. SURVEILLER LES ENFANTS. GARDER

ELECTRICAL RATING (COURANT NOMINAL):	120 VOLTS	60 HERTZ	LESS THAN 3.5 AMPERES
DO NOT REMOVE OR COVER THIS LABEL			
VEUILLEZ A NE JAMES ENLEVER NI DISSIMULER CETTE ÉTIQUETTE			65-01-01421

MODEL: DXV-35 DT4 LX

SN: 4152-

Figure 5-4 Listing Label

5.10.3 Can I use my Fireplace during power outages?

This electronic ignition system uses the supplied 110VAC power when it is available for all functions of this system. If the AC power is interrupted during a power outage, locate the backup battery holder on the far-right side of the courtesy panel behind the lower grill.

During the power outage, the fireplace's burner will function as well as the flame height adjustment. The fan and accent light, which are dependent on 110VAC power, will not function.

Your installer should demonstrate the backup DC power pack during power outages. Be sure to retain the DC battery pack and the connecting harness in a safe and secure place for use during power outages.

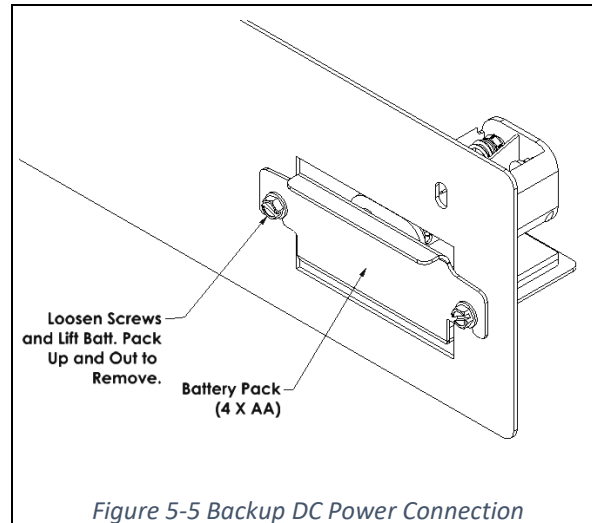

5.10.4 What maintenance is required?

5.10.4.1 Required Annual Maintenance

The following procedures must be performed each year by a qualified installer, service agency or the gas supplier.

Note: Any adjustments to burner, pilot or logs must be done by a qualified installer, service agency or the gas supplier.

Recommended steps for yearly maintenance:

1. Clean all lint and dust build-up around the control. Inspect the condition of any wiring under the burner for melting or damage.
2. Clean pilot light flame sensor rod and sparker rod using emery cloth. Vacuum clean pilot light assembly.
3. Visual check of pilot flames is required. Pilot flame must overlap flame sensor and burner ignition ports always. Especially for LP gas applications, always verify visible pilot flame length is at least 1" long.
4. Vacuum all burner ports. Be sure the burner ports are "open".
5. Visual check of main burner's rear and front flames is required.
6. Remove logs and coals and clean away any foreign matter (lint, carbon, etc.) on the burner and logs.
7. Clean under side of the logs for any carbon deposits. Note: Logs should be visually checked for carbon buildup. If carbon deposits are visible on logs, unit should be turned off and a qualified installer, service agency or the gas supplier contacted. Be sure logs are re-installed per instructions.
8. Check condition of glass door gasket, gasket must seal tightly over firebox. Inspect gasket along top and sides of glass. If gasket bulb along top edge or side top areas are discolored to a white color appearance (through the whole thickness of the gasket bulb in a 3" to 12" long area) and the gasket adhesive is no longer functional to stick to glass, then replace the gasket.
9. Visually inspect the vent terminal (vent cap) for leaves, twigs and other debris accumulation. Clean if required.
10. Clean door glass.
11. Clean enamel firebox lining, if one is installed.

5.10.4.2 Periodic Inspection

Follow these steps for periodic inspections:

1. Check to verify that the vent system and vent cap are open and free of blockage.
2. Before re-installing glass, have qualified service person check the operation of the pilot and cycle the burner per lighting instructions. Be sure all items in lighting and installation checklists are completed.
3. Periodic visual check of pilot flames is required. Pilot flame must overlap flame sensor and burner ignition ports always. Especially for LP gas applications, always verify visible pilot flame length is at least 1" long.
4. Periodic visual check of main burner's rear and front flames is required.

5.10.5 How do I clean the viewing glass?

The viewing glass should be cleaned periodically. Exterior glass surface may be cleaned with cleaner as desired. To clean interior glass surface, use Kel Kem Polish Plus (part # 65-06-00455) or a comparable product. **Caution: Do not** use oven cleaner to clean glass. **Clean the glass only when it has cooled to room temperature.**

Additives that are put in gas (both natural and propane) to make it smell can be harmful to glass and can leave a white film deposit on the glass. This deposit can be removed, if cleaned in a timely manner, with cleaners such as KEL KEM "Polish Plus" (part # 65-06-00455) or comparable product (contact your dealer).

5.10.6 Is my flame performance correct?

Your fireplace has air shutters, dampers, coals, and embers that can be adjusted depending on your fuel and venting configuration. These adjustments should be made by a qualified technician to achieve the best flame performance. Contact your installer or Mendota dealer if you feel your fireplace is not burning correctly. Improper setup and adjustment is not covered under warranty.

5.10.7 What should I do if my fireplace is sooting?

Sooting is caused by improper installation or air shutter operation. However, some small areas of soot deposits on log surfaces are deemed acceptable. If you observe large soot areas (larger than 1"x1") on log surfaces or signs of sooting on the door glass (usually a thin black film on the Fireplace viewing glass or on the outside of the home around the vent cap), the unit must be immediately turned off and the local Mendota dealer promptly informed. Mendota dealers will correct "sooting" problems, but Mendota and their dealers are not responsible for damage caused by excessive sooting that has not been immediately brought to their attention. Troubleshooting soot:

Issue:	Possible Causes:	Corrective Action:
Thin black coating (soot) forms on viewing glass.	A. Burner Air Shutter closed too much. B. Exhaust Damper is closed too much. C. Improper log and/or ember placement D. Glass door seal is compromised. E. Incorrect gas pressure or burner orifice size.	Open air shutter on burner fully. Check exhaust damper position. It may be closed too far. Open exhaust damper. Check glass gasket for proper seal. Corners of glass gaskets cannot be bulging out. If glass gasket along top edge in the middle is white in color across entire thickness of gasket bulb and gasket adhesive is not functional, replace glass gasket. If sooting continues, shut off unit and call Mendota service person. Have service person check for proper Orifice Sizes and correct gas outlet pressure (3.5" W.C. Nat. Gas; 10" W.C. LP Gas). NOTE: To clean glass - remove glass and wipe glass with cloth or paper towel.

5.10.8 How do I change from Celsius to Fahrenheit?

To change between °C to °F, follow these steps:

4. Press the ON/OFF button and turn off the fireplace.
5. Simultaneously, press both the mode button and the thermostat button.
6. Look at the LCD display to verify that your desired indicator (°F or °C) is being displayed.

If not, repeat Step 2.

5.10.9 When do I change batteries in my remote?

When the remote-control batteries are low, a battery icon will appear on the LCD display of the remote control before all battery power is lost. When the batteries are replaced, this icon will disappear.

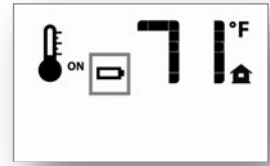

5.10.10 How do I set the child-lock mode?

To prevent unsupervised children from operating the fireplace, a child-lock function is provided with this remote-control system.

To activate the child-lock function: Simultaneously press the "MODE button" and the "UP button".

To deactivate the child-lock function: Simultaneously press the "MODE button" and the "UP button".

During the child-lock mode, none of the remote-control buttons will function. You must deactivate the child-lock function before you can use the remote control.

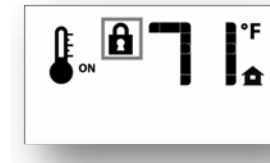

5.10.11 Thermostat icon disappeared from my remote.

When reinstalling batteries, the thermostat button may have been pressed. To make your thermostat icon reappear, follow these steps:

1. Remove one battery.
2. Press and hold the thermostat button on the remote.
3. Reinstall the battery while holding the thermostat button down.
4. If you see "set", the thermostat button is now enabled.
5. If you see "clear", the thermostat button is disabled.
6. Repeat this procedure if you did not see "set" or "clear" to add/remove the thermostat option.

5.10.12 Why won't my fireplace turn on?

If your remote control is working, but your fireplace won't turn on, your fireplace may be in "lockout" mode.

How to reset a lockout:

1. Turn off remote.
2. Turn on remote and wait two seconds.
3. Turn off remote and wait two seconds.
4. Turn on remote and wait two seconds.
5. Turn off remote.

This should clear the lockout mode. Turn on the remote and start the fireplace.

Ensure the master switch is in the run/on position.

After completing these steps, contact your Mendota dealer if fireplace won't turn on.

5.10.13 What happens when I first light my fireplace?

When you first light your fireplace, the initial curing phase is initiated. During the initial curing phase, a small amount of smoke and odor will be emitted. This is normal. To complete the curing process, run your fireplace, on high fire, for two hours with the fans on level 3. Open doors and windows to dissipate any odor. Turn your fireplace off. After it has cooled, run it again, on high fire, with the blowers off until no smoking or odor remains. Refer to [Chapter 3.1.1 Mendota Fireplace Curing Instructions](#) for more information.

6 MAINTENANCE INFORMATION

6.1 REQUIRED PERIODIC INSPECTIONS

1. Check to verify that the vent system and vent cap are open and free of blockage.
2. Have qualified service person check the operation of the pilot light. Pilot light must light within the first five to eight seconds of ignitor sparks initiation. If it takes more ten seconds to ignite the pilot flame, check pilot spark rod position and ignitor wires for pinched areas or damaged areas.
3. Pilot rectification time must be checked. Pilot flame should rectify the ignition system within five seconds of pilot flame ignition and sparking at pilot must stop with five seconds. If pilot flame ignites but sparking continues at pilot hood after five seconds, it indicates that pilot flame sensor is dirty. Clean pilot flame sensor using emery cloth and retry. If problem persists, check flame sensor lead wire for damage or grounding problems and correct.
4. Periodic visual check of pilot flames is required. Pilot Flame must overlap Flame Sensor and burner ignition ports always. Especially for LPG applications, always verify visible pilot flame length is at least 1" long, minimum.
5. Cycle the burners to make certain burner ignition is prompt and flame propagation along burner length is quick and smooth. If flame propagation is delayed, remove obstructing debris, vacuum burner ports and retry.
6. Periodic visual check of rear and front burner flames pattern is required.

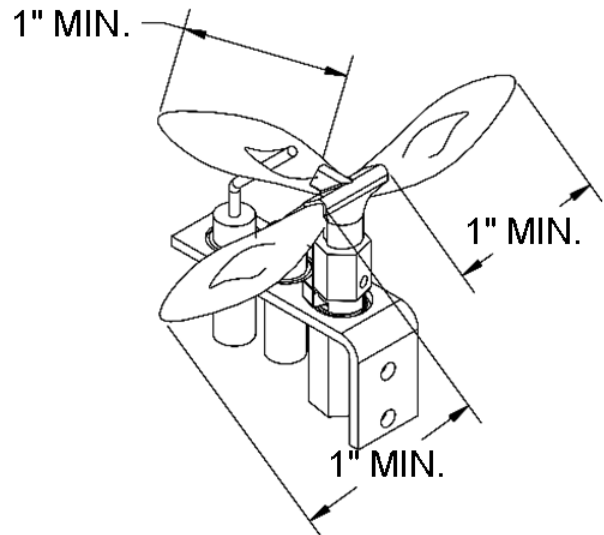

Figure 6-1 Minimum Pilot Flame Length

6.2 CLEANING VIEWING GLASS

WARNING: Do not clean when glass is hot.

The viewing glass should be cleaned periodically. Exterior glass surface may be cleaned with cleaner as desired. To clean Interior glass surface, remove glass frame assembly. See 4.2.6 How to Remove Door. Use Kel Kem "polish plus" (part # 65-06-00455) or comparable product to clean glass interior surface. Do not use oven cleaner or abrasive cleaners to clean glass.

6.3 REQUIRED ANNUAL MAINTENANCE

See Chapter 5.10.4 What maintenance is required?

In addition to the "Required Periodic Inspections", the following procedures must be performed each year by a qualified installer, service agency or the gas supplier. Any adjustments to burner, pilot or logs must be done by a qualified installer, service agency, or the gas supplier.

Clean all lint and dust build-up around the control and blowers. Inspect the condition of any wiring under the burner for melting or damage. Clean flame sensor rod/hook using emery cloth. Vacuum all burner ports and pilot assembly.

Remove logs & coals and clean away any foreign matter (lint, Carbon, etc.) on the burner and logs. Be sure the burner ports are "open". Clean the pilot and under side of the logs for any Carbon deposits.

NOTE: Logs should be visually checked for Carbon "build-up". If heavy carbon deposits are visible on logs, unit should be turned off and a qualified installer, service agency, or the gas supplier should be contacted. Be sure logs are re-installed per instructions.

Check glass gasket seal. Visually inspect glass gasket, especially at the corners of the glass piece. Glass gasket is installed as a 4-piece assembly. Check joints between the gasket pieces at the corners. They should butt against each other to create a seal. Gaps between gasket pieces can cause exhaust leaks and lead to acrid smell concerns.

6.4 OVER FIRING OR UNDER FIRING OF BURNER

NEVER "over fire" or "under-fire" units by increasing or decreasing the main orifice sizes or by adjusting gas pressure to increase BTUH above nameplate specifications.

Over firing can cause permanent damage to firebox and deterioration of parts and void the warranty.

Under-firing can potentially cause delayed ignition and lead to property loss and person injury and will void the warranty.

If you are using a "backyard" Natural Gas well as the gas source, you must submit formal gas analysis data sheets to Mendota Fireplaces for review and calculation of proper main burner orifice sizes prior to first firing. It is known that unpurified Natural Gas from "backyard" wells can contain high energy levels causing over firing. Further, unpurified gas can contain high levels of Sulphur and other compounds which can damage the burner materials and the ceramic glass. Use of unpurified gas will void the warranty for this product.

6.5 IGNITION SYSTEM LOCKOUT MODE AND RE-LIGHTING

If ignition system goes into lockout mode, be sure to wait a minimum of five minutes before attempting to re-light. If lockout occurs frequently, contact you Mendota Dealer for diagnosing the problem.

Frequent lockout can be caused by many factors and must be properly diagnosed, and the primary cause identified. It should never be assumed that the ignition control system is faulty without proper diagnosis.

6.6 BURNER FLAME HEIGHTS REFERENCE DIAGRAM



Figure 6-2 Burner Flame Heights: This image provides a visual reference for the burner flames burning at maximum height after the burners have been operating for 30 minutes or longer. A normal rear flame will be 1 to 2 inches above the rear log top edge. This, however, is dependent on the gas type, air shutter opening setting and vent system configuration. Actual flame heights can be slightly higher or lower when compared to this reference image.

6.7 REPLACEMENT PARTS INFORMATION

6.7.1 How to Access Components

The descriptions below show where the main fireplaces components are located and how to access them for service. The descriptions show how to access the components after the fireplace has been installed. All components are also accessible from the outside of the unit before the fireplace is installed.

Pilot: The pilot light is located on the right side the firebox to the right ends the burners.

Gas Valve: The main gas valve is located behind the lower grill and beneath the firebox.

Complete Valve Assembly: To make working on components easier, this fireplace has been designed with the valve, pilot, shutter boxes, shutter cables and gas lines as part of one assembly that can be removed from the fireplace. To remove the assembly first remove burners and burner airbox. After disconnecting the gas line and wires, below the firebox, remove hex nuts that secure the valve mounting plate to firebox floor. Lift up and remove the entire assembly from the firebox.

Ignition Control Module: The ignition control module is mounted beneath the firebox on the floor. Access to the ignition control module is available by removing the courtesy panel. The ignition control module is affixed with Velcro to the floor.

Convection Blowers: The convection blowers are mounted on the firebox's rear wall. To access the convection blowers, remove the Valve Assembly first.

Accent Light: The accent light is mounted in the firebox top center area. The accent light wire harness is run from the light housing to the left side and then down to the ignition control module.

6.7.2 General Replacement Parts List

PART NO	DESCRIPTION	PART NO	DESCRIPTION
65-02-00103	TADPOLE GLASS GASKET (106")	05-04-00050	PILOT ASS'Y. NAT.
65-06-00463	GLASS – FLAT	05-04-00052	LP PILOT ORIFICE
HA-30-00415	DOOR FRAME ASSEMBLY – FLAT	HA-30-00507	LP KIT
35-01-00240	COALS 12 OZ BAG	65-14-00044	REAR ORIFICE (NAT. GAS) # 44
35-01-00239	GLOWING INSWOOL	65-14-00049	FRONT ORIFICE (NAT. GAS) # 49
35-01-00601	FIREBRICK KIT	65-14-00364	REAR & FRONT ORIFICE (LP GAS) 3/64"
70-01-00130	REAR BURNER TUBE WELDMENT	15-02-00120	R H BLOWER WITH MOTOR
HA-82-00408	FRONT BURNER TUBE WELDMENT	15-02-00121	L H BLOWER WITH MOTOR
05-02-00344	SIT VALVE NAT. GAS	65-06-00125	BLACK PAINT - 12 OZ. SPRAY CAN
		65-06-00455	KEL-KEM GLASS CLEANER/POLISH

6.7.3 Convection Air Blower System Parts

Item 1	15-02-00120	BLOWER, RH
Item 2	15-02-00121	BLOWER, LH

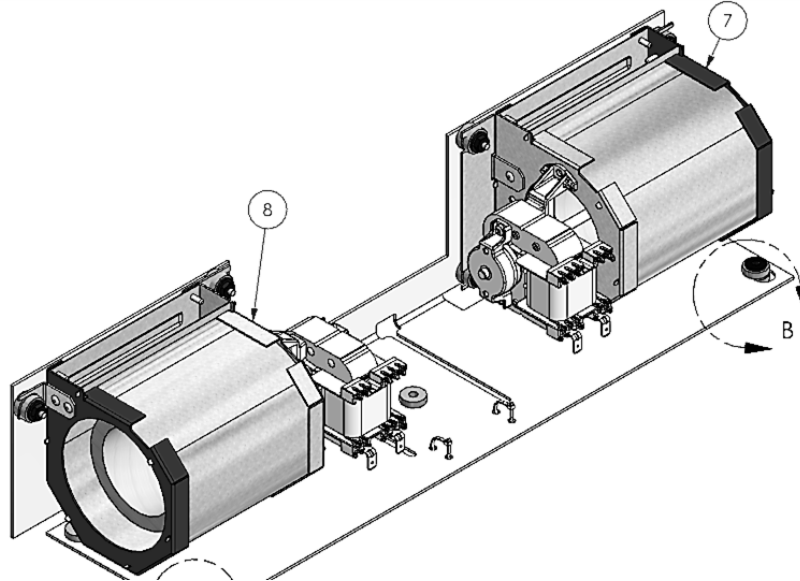

Figure 6-3 DXV35DT4 BLOWER ASSEMBLIES

6.7.4 Accent Light Parts

Item #1	Ha-58-04606	ACCENT LIGHT HOUSING
Item #2	10-11-00020	LIGHT BULB, G9 XENON, 25W
Item #3	10-11-00025	ACCETN LIGHT LENS -2016
Item #4	HA-88-00168	LENS RETAINER BRACKET W/ GASKET
Item #5	HA-77-00357	LIGHT COVER CLIP

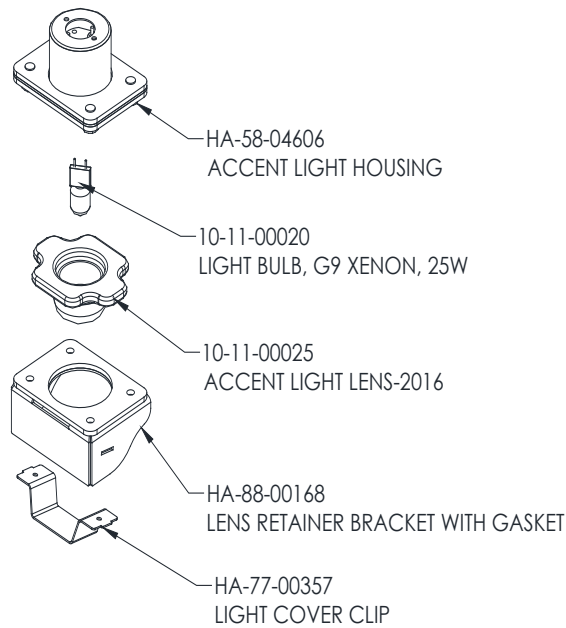

Figure 6-4 ACCENT LIGHT PARTS

6.7.5 Valve Assembly Replacement Parts

Item 1	65-14-00044	Rear Orifice, #44
Item 2	65-14-00049	Front Orifice, #49
Item 3	05-04-00074	Pilot Assembly, 3-way hood
Item 4	05-02-00396	Rear Burner Solenoid Valve
Item 5	05-02-00344	Main Gas Valve

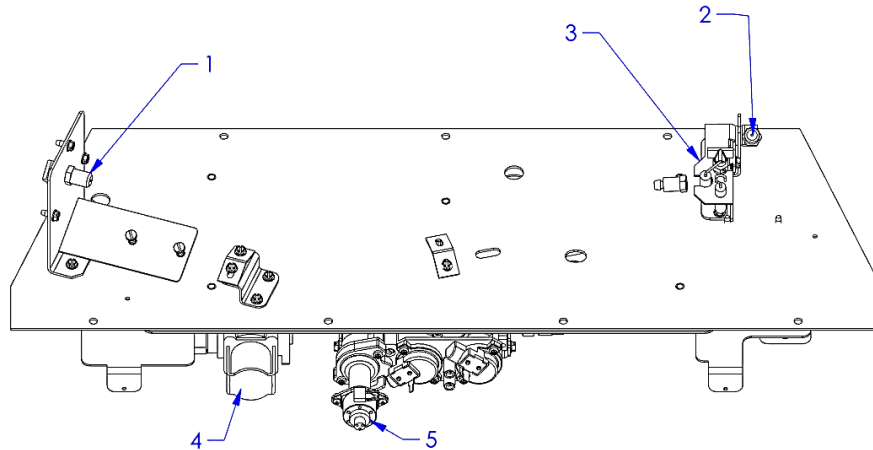

Figure 6-5 Valve Assembly Replacement Parts

6.7.6 Glass Frame Parts Replacement Procedure

WARNING: do not use substitute materials. All replacement materials must be certified and obtained through Mendota fireplaces.

TO REPLACE DAMAGED GLASS

1. Bend glass retainer tabs up 90 degrees. Four tabs hold down the glass and gasket assembly.
2. Remove the damaged glass and gasket material. Clean the inner surface of the glass frame.
3. Assemble new gasket on glass edge starting with the bottom left corner. The adhesive on the gasket should contact the glass surface. Use tracer lines in gasket to determine where the glass should sit on the gasket surface.
4. Place glass and gasket assembly in glass frame and carefully bend down glass retainer tabs. Extra glass retainer tabs are provided should any originally used tabs break off.

The glass frame assembly and its individual components are available through Johnson Gas Appliance Company. Contact your dealer for more detailed ordering information.

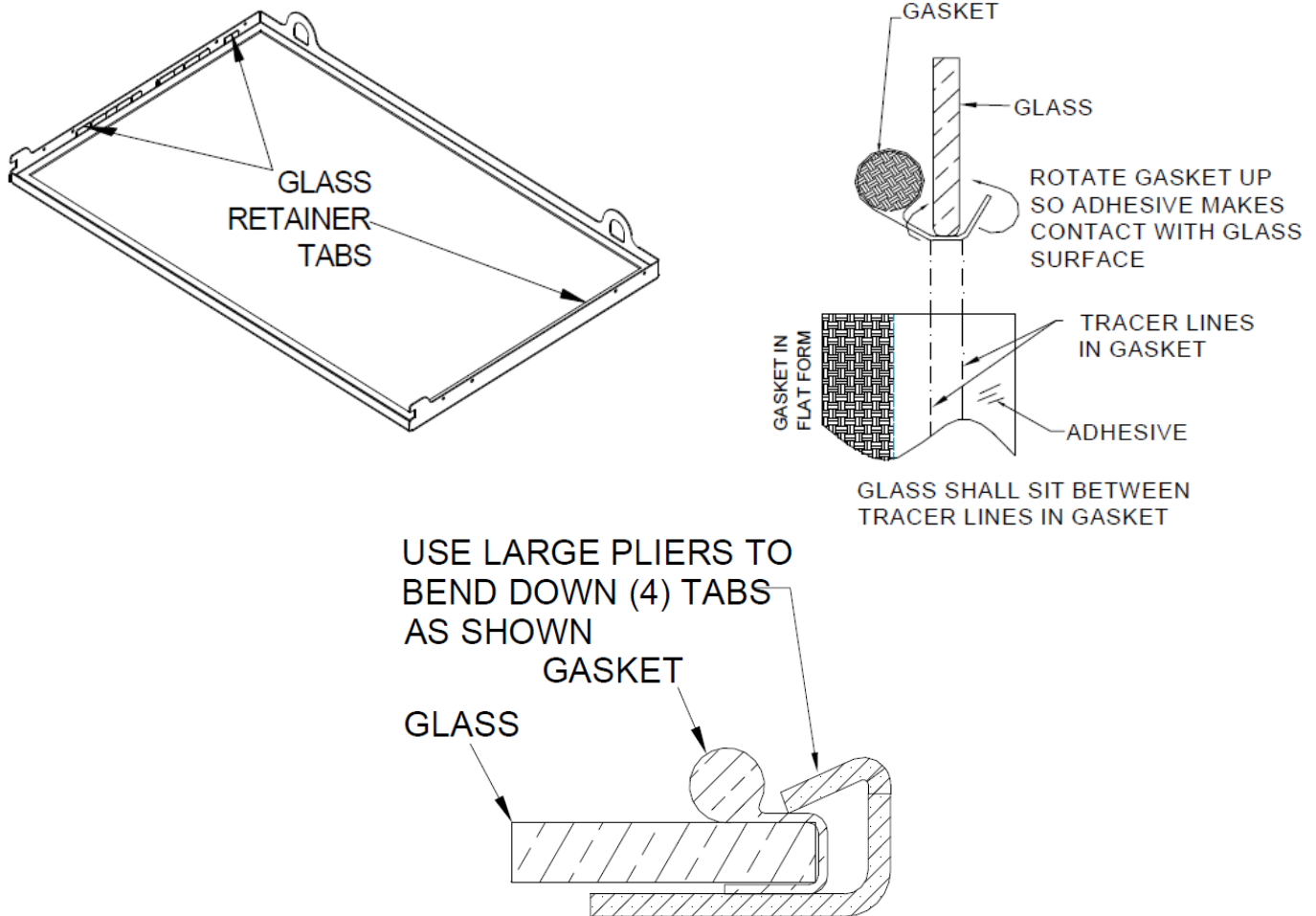

GLASS FRAME ASSEMBLY (HA-30-00415)		
REPLACEMENT PARTS LIST		
ITEM	PART NUMBER	DESCRIPTION
1	HA-29-00522	FRAME, GLASS, DXV35DT4
2	65-02-00103	GASKET, TADPOLE, 5/8" BULB, 3/4" TAIL, 110"
3	65-06-00463	GLASS, CERAMIC, DXV35DT4

7 WARRANTY QUALIFICATION AND SERVICE

The following information verifies proper installation and operation of your Mendota fireplace. All installation and operating instructions must be carefully followed. This Mendota fireplace must be installed according to all manufacturers' instructions as per the manual. Only dealer sanctioned and approved installers can install and/or service Mendota hearth appliances and parts. Repairs conducted by an unqualified technician will void this warranty. Proper permits and inspections are required to validate any future warranty claims. Mendota retail partners are 100% responsible for the installation and service of any Mendota appliance, or part thereof, that they sell within Mendota polices. The Mendota retail partners must also facilitate the execution of any warranty related items for the Mendota appliances and parts that they sell, in perpetuity.

7.1 FINAL INSTALLATION AND HOMEOWNER CHECKLIST

- INSERTS ONLY: The existing woodburning fireplace and its chimney system are structurally sound, professionally cleaned, intact and remain woodburning capable (inserts only).
- INSERTS ONLY: If fireplace was re-faced, does the re-facing conform to the guidelines found in this manual regarding the re-facing of woodburning units?
- INSERTS ONLY: Woodburning chimney interior and chimney top cap are inspected and repaired or replaced if damaged.
- No offensive odor emitting materials exist around appliance such as low temp rated adhesives, plastics or others.
- All surrounding finishing materials are conforming to manual requirements.
- Electrical power supply system conforms to NEC and local electrical codes.
- Gas supply must conform to national and local building codes.
- All gas line joints were checked for leaks using gas leak detector solution or a gas sniffer, or were pressure tested if required by local building code.
- All internal gas plumbing joints were checked for leaks using gas leak detector solution or a gas sniffer.
- Glass gasket was inspected and verified that it is sealing properly.
- Gas supply line was bled of air and pilot flame was ignited.
- Pilot flame overlaps burner flame propagation ports properly.
- Burners light and flames travel promptly along entire length of burner.
- Logs/media are installed properly per installation instructions.
- Burner(s) air shutter is adjusted properly. Shutter opening set properly per installation manual.
- Burner flames are "stable" and are not "lifting" off burner.
- Inform owner that an initial curing step is required. Read and follow Mendota Fireplace and Insert Curing Instructions (found on unit and in owner's manual). Smoke will emit during initial curing step.
- Provide owner with contents of owner's manual packet.
 - Owner's manuals, remote control transmitter, glass latch tool, backup battery system, etc.
- Train owner how to remove and reinstall decorative front.
- Train owner how to remove and properly reinstall glass door.
- Inform owner about the glass safety screen barrier requirement.
- Educate owner on remote control functions (ProFlame units only)
 - How to put fireplace in CPI & back into IPI. CPI is suggested during cold season for ease of operation of fireplace
 - How to light the pilot light.
 - How to light the main burners and how to adjust the flame level.
 - How to turn the fan on and adjust fan speed.
 - How to turn on accent light and adjust brightness of light.
 - How to turn the rear burner on and off.
 - Explain the 3 thermostatic modes of operations:
 - OFF / Manual operation
 - ON / Fireplace turns ON and OFF to maintain the set temperature.
 - Fan delayed 5 minutes in ON and runs 12 minutes after.
 - SMART / Fireplace adjusts the flame level to maintain the set temperature.
 - Fan delayed 5 minutes in ON and runs 12 minutes after.
- Train owner about lockout mode and how to reset it.
- Train owner how to use backup battery system and operate appliance during power outage.
- Train owner about master switch location and emergency shutoff function.
- Train owner how to operate manual shutoff gas valve using glass latch tool.
- Inform owner that periodic maintenance of this unit is required per manual.

WARNING: MENDOTA GAS FIREPLACES ARE HEAT PRODUCING APPLIANCES. KEEP CHILDREN AND FURNITURE A SAFE DISTANCE AWAY TO PREVENT PROPERTY DAMAGE, PERSONAL INJURY OR LOSS OF LIFE.

I have trained and informed homeowner of all the requirements listed above.

Staff Name _____

Staff Signature Date _____

Homeowner's Name _____

Homeowner's Signature Date _____

7.2 WARRANTY POLICY STATEMENT

Mendota Fireplace, a division of Johnson Gas Appliance Company, extends this limited lifetime warranty to the original purchaser of this appliance provided the product remains in the original place of installation. The items covered by this limited warranty and the period of such coverage is set forth in the table below. Some conditions apply (see below). The policy is not transferable, amendable or negotiable under any circumstances. The warranty starts from the date of invoice from Mendota to the installing dealer and only applies to new units sold through an authorized Mendota dealer. In the case of new construction, warranty coverage begins on the date of certificate of occupancy of the dwelling or six months after invoice of the final sale of the product from the Mendota dealer, whichever occurs earlier. However the warranty coverage shall begin no later than 24 months following the date of product shipment from Mendota, regardless of purchase date.

MENDOTA WARRANTY BENEFITS					
Description	Parts Coverage				Labor Coverage (Years)
	Lifetime	3 years	2 years	90 days	
Firebox and Heat Exchanger	X				5
Stainless Steel Burner Tubes/Ceramic Burners	X				2
All Castings	X				2
Valve Assembly and all gas control components (Pilot Assembly, Orifices, Thermocouple, Thermopile)		X			2
All other Electrical Components (Ignition Control Boards, Wiring, Switches, Blowers, Blower Control Module, Battery Pack)		X			2
Venting/Venting Components		X			1
Glass (Breakage From Thermal Shock)			X		1
Exterior Painted Finishes			X		1
Exterior Plated Finishes			X		1
Brick Panels and Log Sets (coloration failures only)			X		1
All Firebox Media (Glass Beads, Ceramic Stones, Tumbled Marble)			X		1
All hardware			X		1
Mesh/Glass Safety Barriers			X		1
Glass Panels			X		1
Enamel Panels			X		1
Remote Control Systems				X	0
Accent Light Bulbs				X	0

X = Mendota Standard Warranty

****Labor credits do not include travel time/mileage and are covered at a subsidized rate, see #4 below for additional details.**

****Parts credits do not include freight.**

7.2.1 Conditions

1. Warranty protects against defect in manufacture or Mendota factory assembled components only, unless herein specified otherwise. Warranty does not cover water damage or odors caused by water or environmental factors.
2. It remains the full responsibility of the owner to operate this appliance within the guidelines provided in the Installation and Operating Instructions Manual accompanying this appliance. Further, the owner shall bear full responsibility to enforce clearances to combustibles requirements and cautioning others about hot glass surface and hot metal surfaces.
3. Owner by operating this appliance accepts that this is a heat producing appliance which has glass and steel parts that are hot enough to cause severe burns. Owner accepts that this appliance requires close monitoring of children and vulnerable individuals who are in the vicinity of this appliance when it is in operation. Mendota does not assume or accept any liability claims for burns or other physical or material damages resulting from touching hot glass surface and hot metal surfaces that are part of this appliance or other adjacent object such as hearth pads and mantels that may heat up during operation of this appliance.
4. Any part(s) found to be defective during the warranty period as outlined above will be repaired or replaced at Mendota's option through an accredited distributor, dealer or pre-approved and assigned agent provided that the defective part is returned to the distributor, dealer or agent for inspection if requested by Mendota. Alternatively, Mendota may at its own discretion fully discharge all of its obligations under the warranty by refunding the verified purchase price of the product to the original purchaser. The purchase price must be confirmed by the original Bill of Sale.
5. The authorized selling dealer, or an alternative authorized Mendota dealer if pre-approved by Mendota, is responsible for all infield diagnosis and service work related to all warranty claims. Mendota is not responsible for results or costs of workmanship of unauthorized Mendota dealers or agents in the negligence of their service work.
6. At all times Mendota reserves the right to inspect reported complaints on location in the field claimed to be defective prior to processing or authorizing of any claim. Failure to allow this upon request will void the warranty.
7. All warranty claims must be submitted by the dealer servicing the claim, including a copy of the Bill of Sale (proof of purchase by you). All claims must be complete and provide full details as requested by Mendota to receive consideration for evaluation. Incomplete claims may be rejected. Unit must be installed according to all manufacturers' instructions as per the manual by a Mendota authorized dealer, an authorized dealer technician or an authorized dealer service person only.
8. All Local and National required codes must be met.
9. The installer is responsible to ensure the unit is operating as designed at the time of installation.
10. The original purchaser is responsible for annual maintenance of the unit, as outlined in the owner's manual. As outlined below, the warranty may be voided due to problems caused by lack of maintenance.
11. Repair/replacement parts purchased by the consumer from your local Mendota Dealer after the original coverage has expired on the unit will carry a 90-day warranty, valid with a receipt only. Any item shown to be defective will be repaired or replaced at our discretion. No labor coverage is included with these parts. Parts requested to be drop shipped direct to the consumer will nullify this warranty.

7.2.2 Exclusions

1. This limited warranty does not extend to paint, rust or corrosion of any kind due to a lack of maintenance or improper venting, combustion air provision, corrosive chemicals (i.e. chlorine, salt, air, etc.), door or glass gasketing.
2. Discoloration and some minor warping are normal, not a defect and therefore not covered under this warranty. The installer must ensure the unit is burning as per the rating tag at the time of installation. Over-firing (operation above the listed BTU rating of this unit can cause serious damage and will nullify this warranty.
3. Mendota will not cover the cost of the removal or re-installation of hearths, facing, mantels or other components.
4. The first service call is at the expense of the Retailer/Installing Dealer, Labor Credit is NOT allowed for normal dealer services. This includes but is not limited to; flame adjustment, venting, log placement or replacement, pilot adjustment, gas leaks, remote controls, light bulb replacement, multiple trips to diagnose and order parts, or annual maintenance, back-order delays, freight costs, mileage, etc. Claims MUST be submitted within 15 days of service and MUST be accompanied by a copy of the Mendota invoice (for the warranted part) for parts credit or to issue an RMA. All labor rates paid to authorized dealers are subsidized rates. Dealers may charge homeowner for travel and additional time beyond their subsidy.
5. Damages to plated surfaces caused by fingerprints, scratches, melted item or other external sources left on plated surfaces from the use of cleaners other than denatured alcohol is not covered by this warranty. Wipe off any fingerprints prior to using fireplace for the first time to ensure oils from the hands don't etch into plated/finished surface.

6. Mendota is free of liability for any damages caused by the appliance, as well as inconvenience expenses and materials. Incidental or consequential damages are not covered by this warranty.
7. Exclusions to this warranty include: injury, loss of use, damage, failure to function due to accident, negligence, misuse, improper installation, alteration of the manufacturer's setting of components, lack of proper and regular maintenance, damage incurred while the appliance is in transit, or by act of God.
8. Malfunction, damage or performance based issues of any and all components as a result of environmental conditions, location, chemical damages, downdrafts, installation error, installation by an unqualified installer, incorrect chimney components (including but not limited to cap size or type), operator error, abuse, misuse, use of improper fuels, lack of regular maintenance and upkeep, acts of God, weather related problems from hurricanes, tornados, earthquakes, floods, lightning strikes/bolts or acts of terrorism or war, which result in malfunction of the appliance are not covered under the terms of this Limited Lifetime Warranty.
9. Mendota has no obligation to enhance or modify any unit once manufactured (i.e. as products evolve, field modifications or upgrades will not be performed on existing appliances).
10. Any unit showing signs of neglect or misuse will not be covered under the terms of this warranty policy and may void this warranty. This includes units with rusted or corroded fireboxes or water damaged units.
11. Units which show evidence of being operated while damaged, or with problems known to the purchaser and causing further damages will void this warranty.
12. Units where the serial no. has been altered, deleted, removed or made illegible will void this warranty.
13. Noises due to minor movement, expansion and contraction of the steel is normal and is not covered under the terms of this warranty.
14. Freight damages for products or parts are not covered under the terms of the warranty. Please refer to our Freight Damage Policy and follow proper procedures at the time of delivery from Mendota. NOTE: all units should be thoroughly inspected at the time of delivery from freight carrier and reported within 48 hours (does not guarantee claim will be paid). Failure to report damages after 48 hours results in automatic claim denial through the freight carrier and dealer/consumer will be responsible for purchasing replacements.
15. Products made or provided by other manufacturers and used in conjunction with the Mendota appliance without prior authorization from Mendota may void this warranty.

7.2.3 Limitations of Liability

The original purchaser's exclusive remedy under this warranty, and Mendota's sole obligation under this warranty, express or implied, in contract or in tort, shall be limited to replacement, repair, or refund, as outlined above. In no event will Mendota be liable under this warranty for any incidental or consequential commercial damages or damages to property. To the extent permitted by applicable law, Mendota makes no express warranties other than the warranty specified herein. The duration of any implied warranty is limited to the duration of the expressed warranty specified above. If implied warranties cannot be disclaimed, then such warranties are limited in duration to the duration of this warranty.

Some U.S. states do not allow limitations on how long an implied warranty lasts or allow exclusion or limitation of incidental or consequential damages, so the above limitations or exclusions may not apply to you. Customers located outside the U.S. should consult their local, provincial or national legal codes for additional terms which may be applicable to this warranty.

7.2.4 How to Obtain Warranty Service

If you discover a problem that you believe to be covered by the warranty, you must report it to your Mendota Dealer within 30 days, with proof of purchase, purchase date, model name and serial number.

Customers should contact the authorized selling dealer to obtain warranty service. In the event the authorized selling dealer is unable to provide warranty service, please contact Mendota by mail at the address listed below. Please include a brief description of the problem and your address, email and telephone contact information. A representative will contact you to make arrangements for an inspection and/or warranty service.

Warrantor:

Johnson Gas Appliance Company
Mendota Fireplace Division
1155 Sherman Rd., Hiawatha, IA 52233

MENDOTA

NORTH AMERICA'S LUXURY FIREPLACE

MENDOTAHEARTH.COM

1155 Sherman Rd, Hiawatha, IA 52233

(800)553-5422